



Quality Access Doors - FAST!

# SUBMITTAL/TECHNICAL DATA SHEET

## APPLICATION

Provides quick and easy access to flush valves that are concealed in the wall

## FEATURES

- Door panel is removable from the frame via tamperproof stainless steel screws
- A 1-1/2" dia. hole in the center of the panel is provided for the valve handle

## SPECIFICATIONS

**MATERIAL:** 18 gauge stainless steel

**DOOR:** Overlaps frame, completely removable via tamperproof stainless steel screws. Door panel to have 1-1/2" dia. hole in center.

**MOUNTING FRAME:** 1-1/4" deep

**STANDARD LATCH:** Tamperproof stainless steel screws

**FINISH:** Stainless Steel: Type 304-#4 satin polish

SKU: **BA-AFVP**

## FLUSH VALVE PANEL



## DIMENSIONS AND APPEARANCE

>> [CLICK TO VIEW ADDITIONAL DETAILS AND PRICING](#) <<

DOOR SIZE W x H INCHES (MM)	WEIGHT	
	LBS	KG
12 x 12 (305 x 305)	5	2.3
15 x 15 (381 x 381)	9	4.1

For detailed specifications see submittal sheet

MANUFACTURED BY ACUDOR

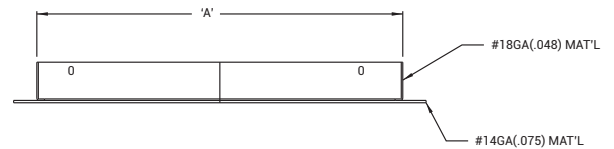
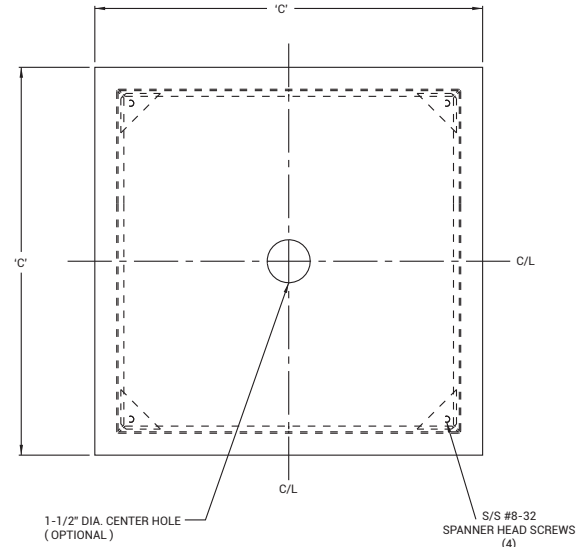
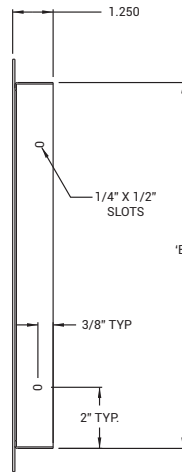

For a complete list of options visit [www.BestAccessDoors.com](http://www.BestAccessDoors.com)

## PROJECT DATA

Custom Sizes Available - Fast!

PROJECT NAME :	QTY	W	H	OPTIONS
ARCHITECT :				
DEALER :				
CONTRACTOR :				
LOCATION :	SPECIAL INSTRUCTIONS :			
DATE :				
TAGGING INSTRUCTIONS :	SUBMITTAL APPROVAL : (signature or stamp)			

Scan or Click



To view Pricing and Additional Product Info.

TELEPHONE:  
1-800-483-0823  
FAX:  
1-888-828-6021



228 PARK AVE. S. #76520  
NEW YORK, NY, 10003



WEBSITE:  
[www.BestAccessDoors.com](http://www.BestAccessDoors.com)  
E-MAIL:  
[info@bestaccessdoors.com](mailto:info@bestaccessdoors.com)

# BA-AFVP

# FLUSH VALVE ACCESS PANEL

NOMINAL DOOR SIZE	A	B	C	D	SCREWS
in. (mm)					
12 x 12 (305 x 305)	9.65 (245)	9.65 (245)	14.75 (375)	14.75 (375)	2
14 x 14 (355 x 355)	11.65 (296)	11.65 (296)	16.75 (425)	16.75 (425)	2

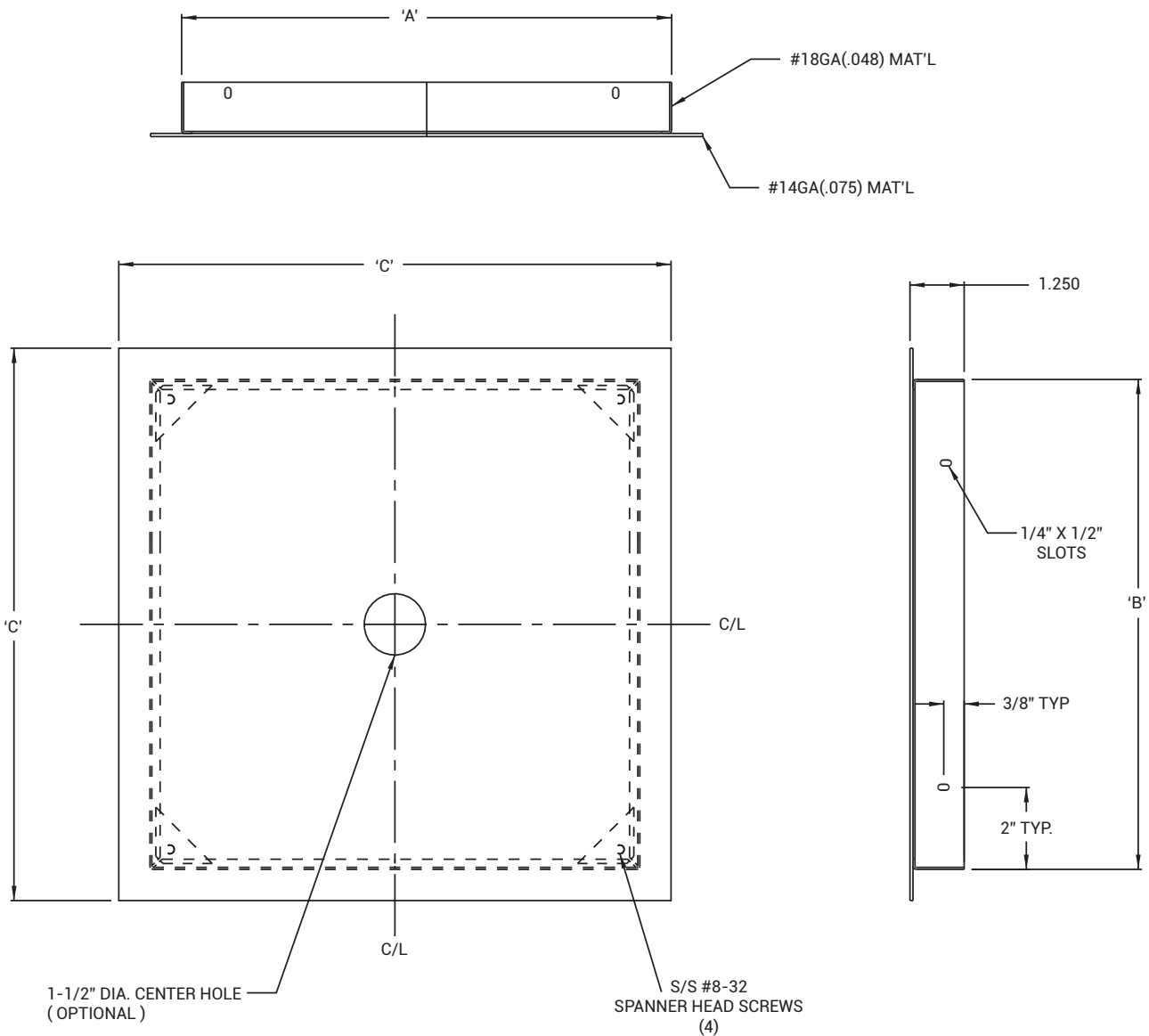

MANUFACTURED BY ACUDOR