



Quality Access Doors- FAST!

# SUBMITTAL/TECHNICAL DATA SHEET

## APPLICATION

Designed for use in acoustical plaster walls and ceilings

## FEATURES

- Door is recessed 5/8" and is lined with self-furring lath
- Expansion casing bead with 3" wide galvanized lath
- Concealed, pivoting rod type hinge

## SPECIFICATIONS

**MATERIAL:** Steel

**DOOR:** 16 gauge recessed 5/8" lined with self-furring galvanized lath

**DOOR FRAME:** 14 gauge expansion casing bead with 3" wide galvanized lath, recessed 3/4" to receive plaster

**HINGE:** Concealed, pivoting rod type. (For wall applications, a continuous exposed piano hinge is suggested.)

**STANDARD LATCH:** Flush to surface, screwdriver operated cam latch

**OPTIONAL LATCHES/LOCKS:** Cylinder lock and key, allen head cam latch, spanner head cam latch

**FINISH:** Steel: 5-stage iron phosphate preparation with prime coat of White alkyd baked-on enamel

SKU: **BA-AP-5010**

## RECESSED ACCESS DOOR

FOR ACOUSTICAL PLASTER WALLS & CEILINGS



## DIMENSIONS AND APPEARANCE

>> CLICK TO VIEW ADDITIONAL DETAILS AND PRICING <<

DOOR SIZE W x H INCHES (MM)	LATCHES	WEIGHT	
		LBS	KG
12 x 12 (305 x 305)	1	8.5	3.9
18 x 18 (457 x 457)	2	15	6.8
24 x 24 (610 x 610)	2	23	10.4
24 x 36 (610 x 914)	4	30	13.8

Wall or ceiling opening is W + 3/8" ( 9 mm)  
For detailed specifications see submittal sheet

MANUFACTURED BY ACUDOR

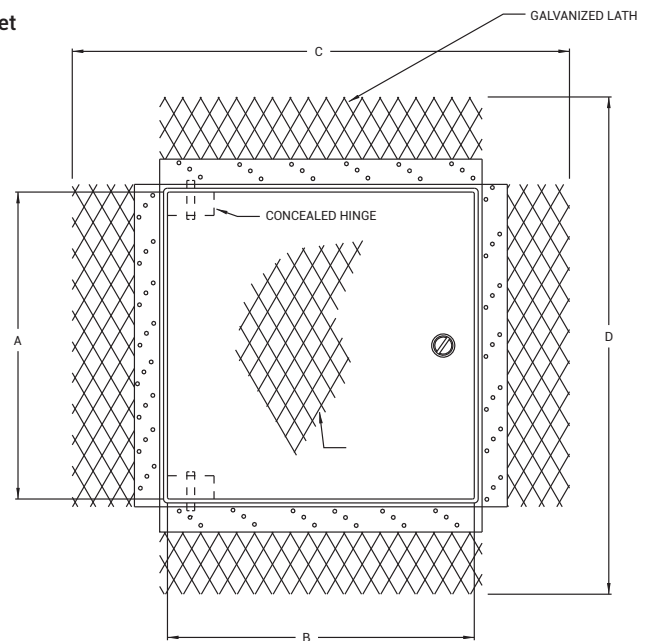
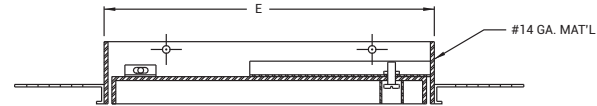
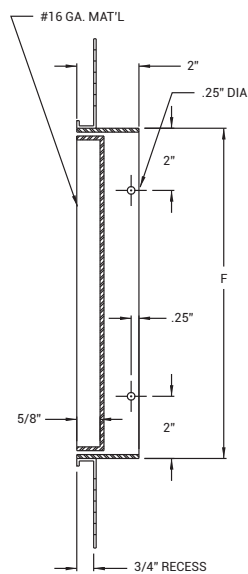

For a complete list of options visit  
[www.BestAccessDoors.com](http://www.BestAccessDoors.com)

## PROJECT DATA

Custom Sizes Available - Fast!

Scan or Click



To view Pricing and Additional Product Info.

PROJECT NAME :	QTY	W	H	OPTIONS
ARCHITECT :				
DEALER :				
CONTRACTOR :				
LOCATION :	SPECIAL INSTRUCTIONS :			
DATE :				
TAGGING INSTRUCTIONS :	SUBMITTAL APPROVAL : (signature or stamp)			

TELEPHONE:  
1-800-483-0823  
FAX:  
1-888-828-6021



228 PARK AVE. S. #76520  
NEW YORK, NY, 10003



WEBSITE:  
[www.BestAccessDoors.com](http://www.BestAccessDoors.com)

E-MAIL:  
[info@bestaccessdoors.com](mailto:info@bestaccessdoors.com)

# BA-AP-5010

## RECESSED ACCESS DOOR FOR ACOUSTICAL PLASTER WALLS AND CEILINGS

NOMINAL DOOR SIZE	A	B	C	D	E	F	LOCK
Inches (mm)							
12 x 12 (305 x 305)	11.81 (300)	11.81 (300)	18.00 (457)	18.00 (457)	12.00 (305)	12.00 (305)	1
18 x 18 (457 x 457)	17.81 (452)	17.81 (452)	24.00 (610)	24.00 (610)	18.00 (457)	18.00 (457)	2
24 x 24 (610 x 610)	23.81 (605)	23.81 (605)	30.00 (762)	30.00 (762)	24.00 (610)	24.00 (610)	2
24 x 36 (610 x 914)	35.81 (910)	23.81 (605)	30.00 (762)	42.00 (1067)	24.00 (610)	24.00 (610)	2

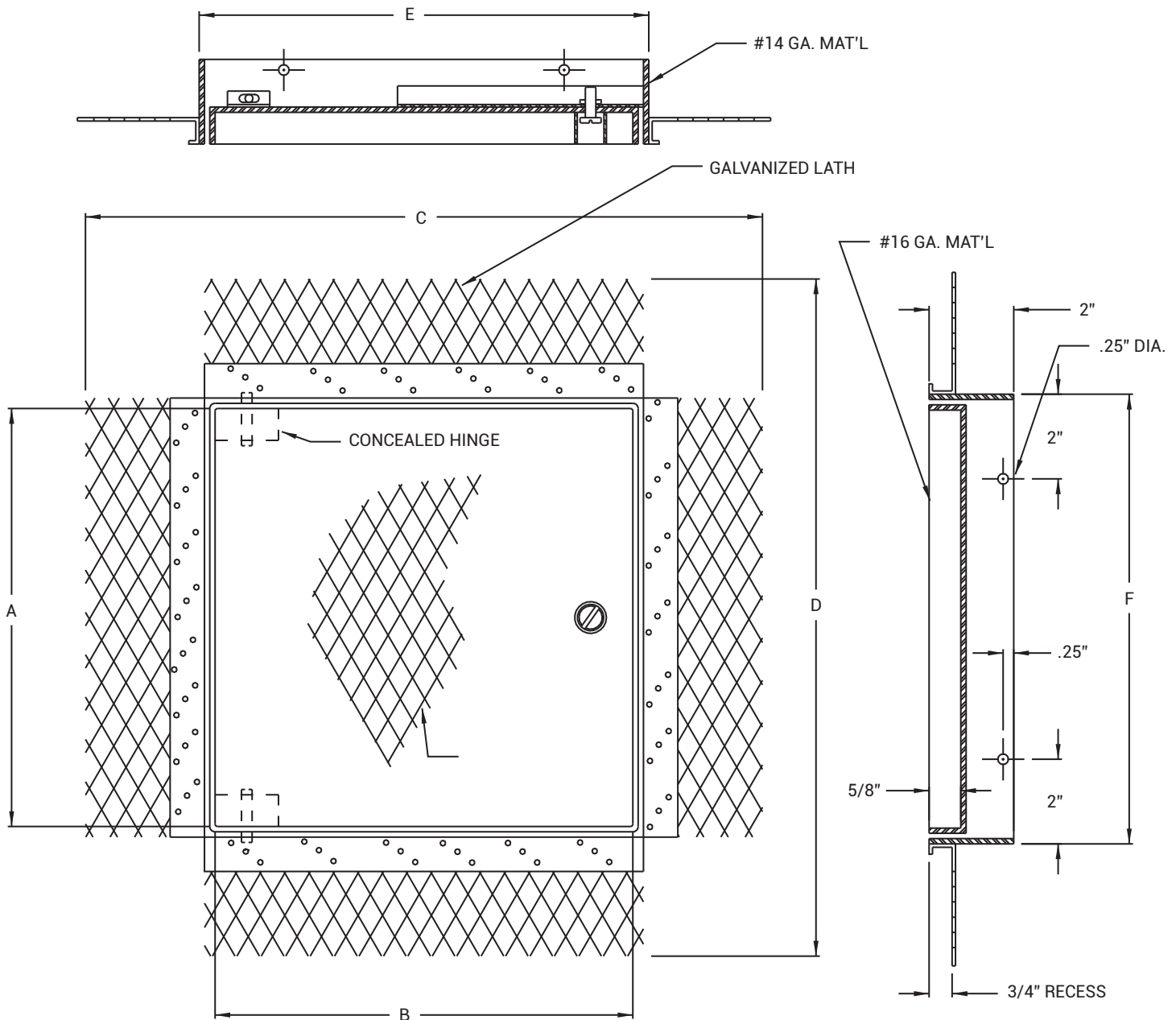

MANUFACTURED BY ACUDOR