



Quality Access Doors- FAST!

SUBMITTAL/TECHNICAL DATA SHEET

APPLICATION

- Designed to provide a gasketed fit in all types of walls and ceilings
- This door is commonly used in clean rooms, laboratories, operating rooms, etc.

FEATURES

- Gasketed access door
- Formed door panel with reinforced edges and a concealed hinge, along with open cell gasket between the door and frame

SPECIFICATIONS

DOOR / DOOR FRAME: 18 gauge door, 18 gauge mounting frame, flange to be 1" wide

HINGE: Concealed

GASKET: Pemko S88 adhesive-backed bulb silicone gasket

STANDARD LATCH: Stainless steel screwdriver operated cam latch

OPTIONAL LATCHES/LOCKS: Cylinder lock & key, allen head cam latch, spanner head cam latch

FINISH: 5 stage iron phosphate with prime coat of White alkyd baked-on enamel

Please note the BA-AS-9000 has not been tested for air penetration. For a door that has been tested for Air & Water penetration see BA-ADWT model

For a complete list of options visit www.BestAccessDoors.com

SKU: **BA-AS-9000**

SPECIALTY DOORS

GASKETED ACCESS DOOR



DIMENSIONS AND APPEARANCE

>> [CLICK TO VIEW ADDITIONAL DETAILS AND PRICING](#) <<

DOOR SIZE W x H INCHES (MM)	WEIGHT	
	LBS	KG
12 x 12 (305 x 305)	6	2.7
16 x 16 (406 x 406)	10	4.5
18 x 18 (457 x 457)	11.5	5.1
24 x 24 (610 x 610)	19	8.4
24 x 36 (610 x 914)	28	12.4

Wall or ceiling opening is nominal door size + 3/8" (9 mm)

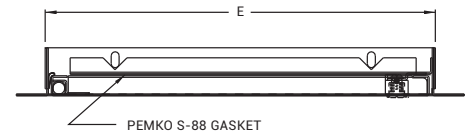

For detailed specifications see submittal sheet

MANUFACTURED BY ACUDOR

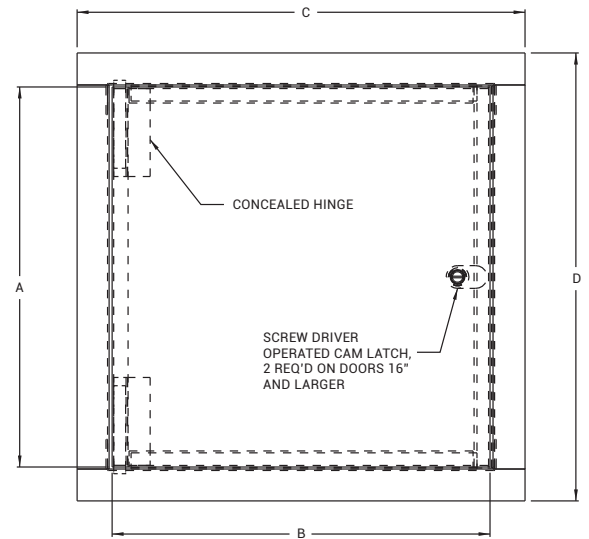
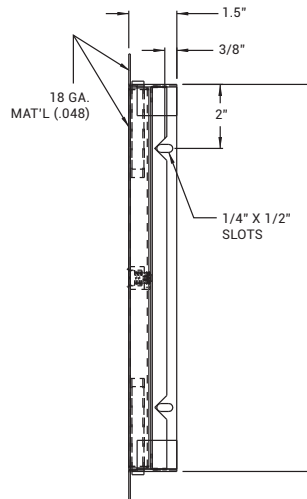

PROJECT DATA

Custom Sizes Available - Fast!

PROJECT NAME :	QTY	W	H	OPTIONS
ARCHITECT :				
DEALER :				
CONTRACTOR :				
LOCATION :	SPECIAL INSTRUCTIONS :			
DATE :				
TAGGING INSTRUCTIONS :	SUBMITTAL APPROVAL : (signature or stamp)			

Scan or Click



To view Pricing and Additional Product Info.

TELEPHONE:
1-800-483-0823
FAX:
1-888-828-6021



228 PARK AVE. S. #76520
NEW YORK, NY, 10003



WEBSITE:
www.BestAccessDoors.com
E-MAIL:
info@bestaccessdoors.com

BA-AS-9000

SPECIALTY DOORS GASKETED ACCESS DOOR

NOMINAL DOOR SIZE	A	B	C	D	E	F	LATCH
in. (mm)							
8 x 8 (203 x 203)	7.875 (200)	7.875 (200)	10.00 (254)	10.00 (254)	8.19 (208)	8.09 (205)	1
12 x 12 (305 x 305)	11.875 (302)	11.875 (302)	14.00 (355)	14.00 (355)	12.19 (310)	12.09 (307)	1
16 x 16 (406 x 406)	15.875 (403)	15.875 (403)	18.00 (457)	18.00 (457)	16.19 (411)	16.09 (409)	2
18 x 18 (457 x 457)	17.875 (454)	17.875 (454)	20.00 (508)	20.00 (508)	18.19 (462)	18.09 (459)	2
24 x 24 (610 x 610)	23.875 (606)	23.875 (606)	26.00 (660)	26.00 (660)	24.19 (614)	24.09 (612)	2
24 x 36 (610 x 914)	35.875 (911)	23.875 (606)	26.00 (660)	38.00 (965)	24.19 (614)	36.09 (917)	2

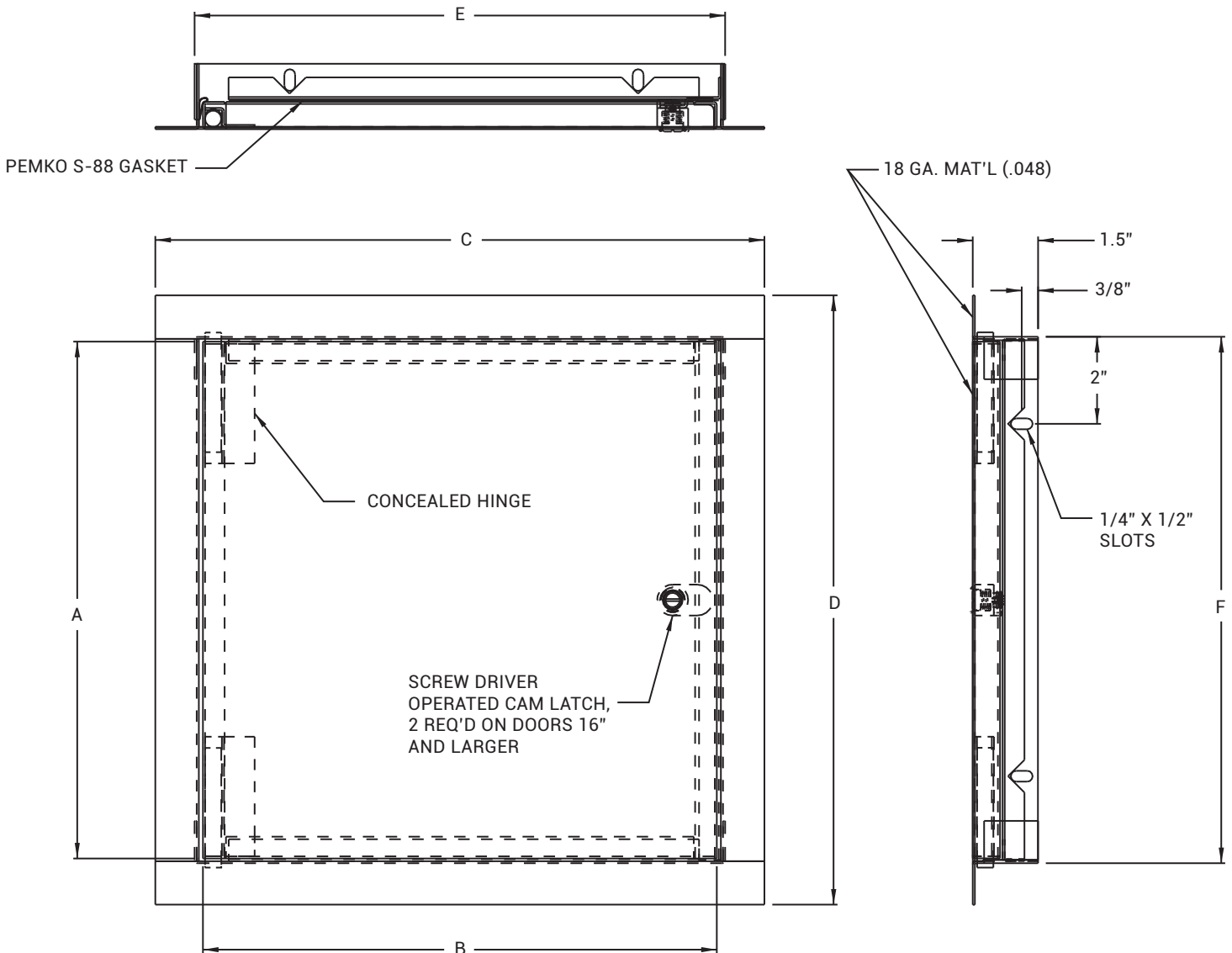

MANUFACTURED BY ACUDOR