



Quality Access Doors- FAST!

SUBMITTAL/TECHNICAL DATA SHEET

APPLICATION

Economical access to high pressure duct

FEATURES

- These doors are for use in high pressure ducts up to 8" static pressure. Pressure rated to 8" W.G. with leakage no greater than 2 CFM per sq. ft. or less.
- 5/8" notched knock over tabs on the inside of the frame provide for easy installation

OPTIONS

Aluminum, stainless steel

SPECIFICATIONS

MATERIAL: Galvanized steel

DOOR: 24 gauge, double panel with high temperature glue.

MOUNTING FRAME: 24 gauge with 5/8" notched knock over tabs.

GASKETING: 1/4" thick by 1/2" wide closed cell neoprene gasketing between door and frame. 1/8" thick by 1/2" wide closed cell neoprene gasketing between frame and duct

INSULATION: Door panel filled with 2" fiberglass insulation (7.7 R factor), compressed into 1".

LATCH: Self tightening, hand operated cam latch

For a complete list of options visit www.BestAccessDoors.com

SKU: **BA-CD-5080-HP**

DUCT DOOR

FOR HIGH PRESSURE DUCTS



DIMENSIONS AND APPEARANCE

>> CLICK TO VIEW ADDITIONAL DETAILS AND PRICING <<

DOOR SIZE W x H INCHES (MM)	OPENING	WEIGHT	
		LBS	KG
6 x 6 (152 x 152)	4.75" X 4.75"	1.00	0.5
8 x 8 (203 x 203)	6.75" X 6.75"	1.25	0.6
10 x 10 (254 x 254)	8.75" X 8.75"	2.00	0.9
12 x 12 (304 x 304)	10.75" X 10.75"	2.50	1.1
14 x 14 (356 x 356)	12.75" X 12.75"	3.25	1.5
16 x 16 (406 x 406)	14.75" X 14.75"	4.00	1.8
18 x 18 (457 x 457)	16.75" X 16.75"	5.50	2.5
20 x 20 (508 x 508)	18.75" X 18.75"	9.00	4.1
24 x 24 (610 x 610)	22.75" X 22.75"	9.00	4.1

Duct opening is normal door size-11/4" or (31 mm)
For detailed specifications see submittal sheet

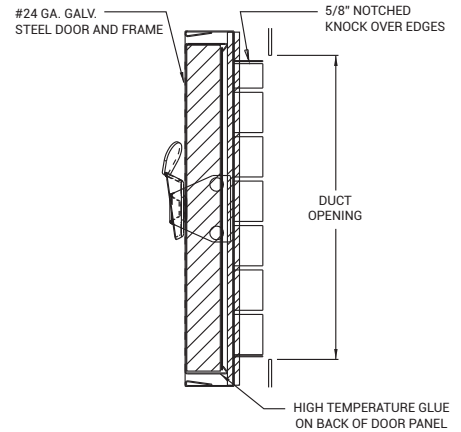

MANUFACTURED BY ACUDOR

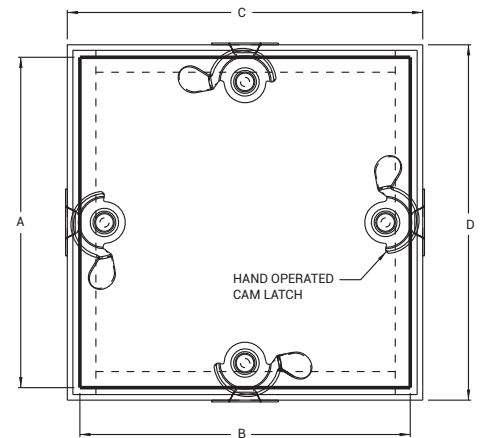
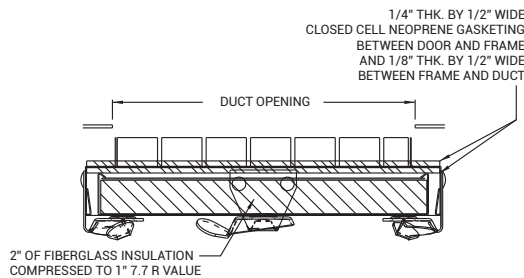

PROJECT DATA

Custom Sizes Available - Fast!

PROJECT NAME :	QTY	W	H	OPTIONS
ARCHITECT :				
DEALER :				
CONTRACTOR :				
LOCATION :	SPECIAL INSTRUCTIONS :			
DATE :				
TAGGING INSTRUCTIONS :	SUBMITTAL APPROVAL : (signature or stamp)			

Scan or Click



To view Pricing and Additional Product Info.

TELEPHONE:
1-800-483-0823

FAX:
1-888-828-6021



228 PARK AVE. S. #76520
NEW YORK, NY, 10003



WEBSITE:
www.BestAccessDoors.com

E-MAIL:
info@bestaccessdoors.com

BA-CD-5080-HP

DUCT DOOR - NO HINGE FOR HIGH PRESSURE DUCTS

NOMINAL DOOR SIZE	A	B	C	D	DUCT OPENING	LATCH
6 x 6 (152 x 152)	5.5 (140)	5.5 (140)	6.0 (152)	6.0 (152)	4.75 x 4.75 (121 x 121)	2
8 x 8 (203 x 203)	7.5 (191)	7.5 (191)	8.0 (203)	8.0 (203)	6.75 x 6.75 (171 x 171)	2
10 x 10 (254 x 254)	9.5 (241)	9.5 (241)	10.0 (250)	10.0 (250)	8.75 x 8.75 (222 x 222)	2
12 x 12 (304 x 304)	11.5 (292)	11.5 (292)	12.0 (304)	12.0 (304)	10.75 x 10.75 (273 x 273)	2
14 x 14 (356 x 356)	13.5 (343)	13.5 (343)	14.0 (356)	14.0 (356)	12.75 x 12.75 (324 x 324)	4
16 x 16 (406 x 406)	15.5 (394)	15.5 (394)	16.0 (356)	16.0 (356)	14.75 x 14.75 (375 x 375)	4
18 x 18 (457 x 457)	17.5 (445)	17.5 (445)	18.0 (457)	18.0 (457)	16.75 x 16.75 (425 x 425)	4
20 x 20 (508 x 508)	19.5 (495)	19.5 (495)	20.0 (508)	20.0 (508)	18.75 x 18.75 (476 x 476)	4
24 x 24 (610 x 610)	23.5 (597)	23.5 (597)	24.0 (610)	24.0 (610)	22.75 x 22.75 (578 x 578)	4

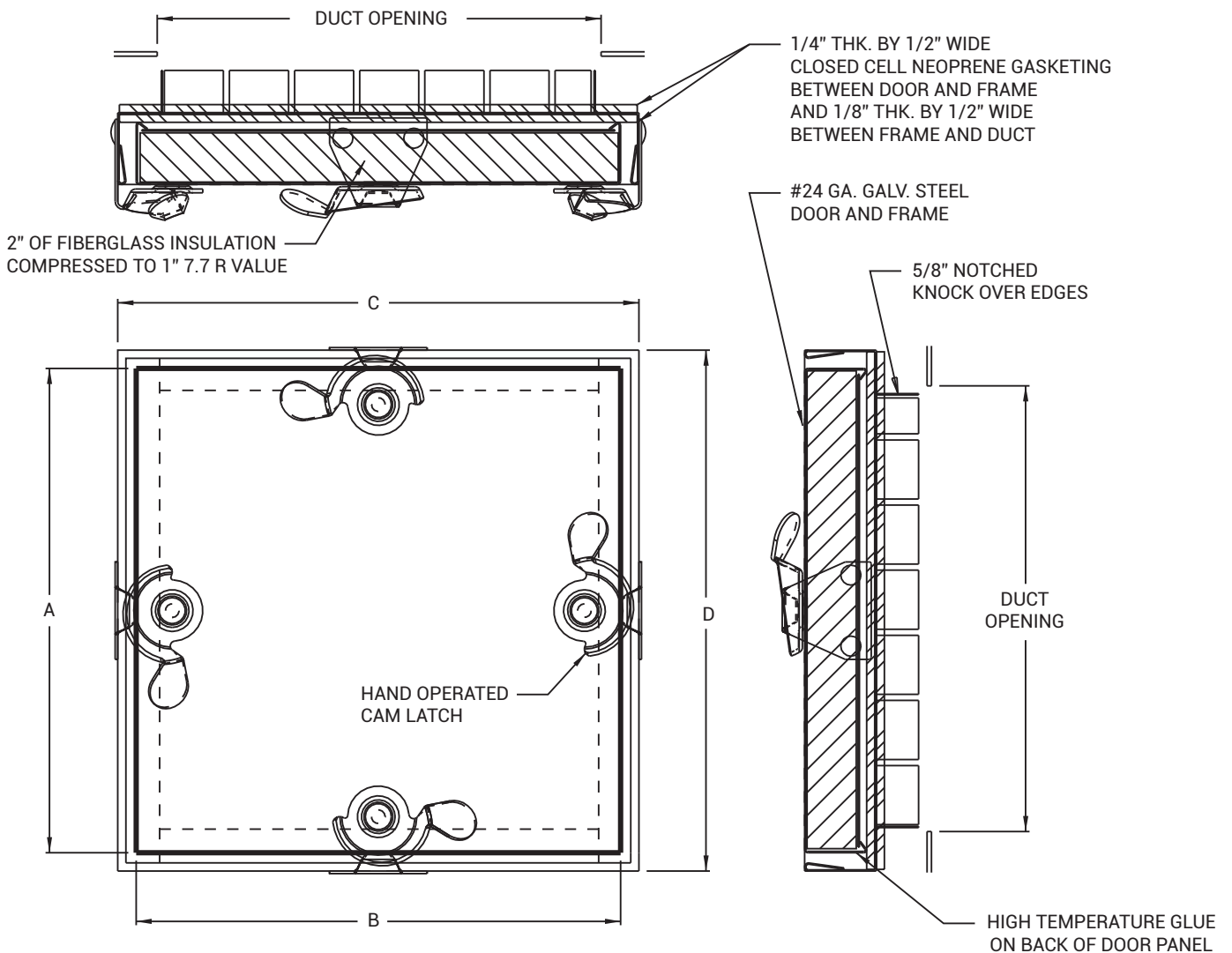

MANUFACTURED BY ACUDOR