



Quality Access Doors- FAST!

SUBMITTAL/TECHNICAL DATA SHEET

APPLICATION

- Designed for use in tiled walls
- Used whenever it is necessary to provide access in fire rated walls, when temperature rise is not a factor

FEATURES

- Recessed 1/2" and is lined with self-furring lath
- Designed to maintain continuity in a 2-hour fire barrier wall



SKU: **BA-FB-5060-TD**

FIRE-RATED UNINSULATED

RECESSED FOR TILE WALLS



DIMENSIONS AND APPEARANCE

>> CLICK TO VIEW ADDITIONAL DETAILS AND PRICING <<

SPECIFICATIONS

MATERIAL: Steel

DOOR: 16 gauge with reinforced edges, door pane recessed 1/2" and lined with self-furring lath.

MOUNTING FRAME: 16 gauge steel

HINGE: Continuous exposed piano hinge

FIRE RATING (WALLS): UL – 1-1/2 hour "B" label. ULC – 2 hour "B" label. (optional) Max size 36 x 48

STANDARD LATCH: Universal self-latching bolt, operated by a flush key. When master keying is required, doors can be prepared for rim or mortise cylinder locks.

FINISH: Steel: 5 stage iron phosphate preparation with prime coat of White alkyl baked-on enamel

DOOR SIZE W x H INCHES (MM)	LATCHES	WEIGHT	
		LBS	KG
12 x 12 (305 x 305)	1	8.30	3.80
16 x 16 (406 x 406)	1	11.5	5.15
18 x 18 (457 x 457)	1	14.3	6.50
24 x 24 (610 x 610)	1	20.3	9.20
26 x 36 (610 x 914)	2	30.0	13.6

Wall opening is W + 3/8" (9 mm)

For detailed specifications see submittal sheet

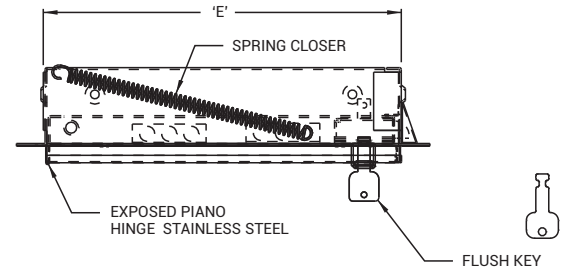

MANUFACTURED BY ACUDOR

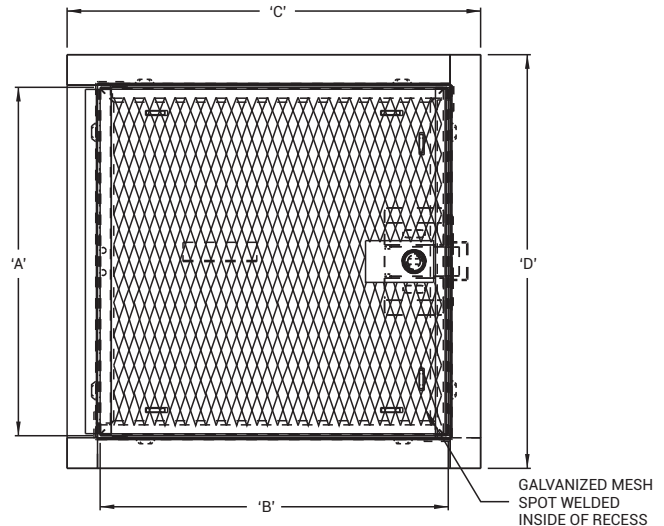
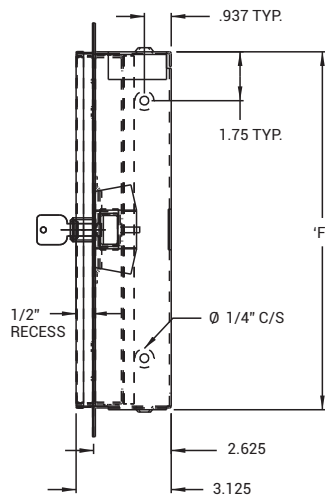

For a complete list of options visit www.BestAccessDoors.com

PROJECT DATA

Custom Sizes Available - Fast!

Scan or Click



To view Pricing and Additional Product Info.

PROJECT NAME :	QTY	W	H	OPTIONS
ARCHITECT :				
DEALER :				
CONTRACTOR :				
LOCATION :	SPECIAL INSTRUCTIONS :			
DATE :				
TAGGING INSTRUCTIONS :	SUBMITTAL APPROVAL : (signature or stamp)			

TELEPHONE:
1-800-483-0823
FAX:
1-888-828-6021



228 PARK AVE. S. #76520
NEW YORK, NY, 10003



WEBSITE:
www.BestAccessDoors.com
E-MAIL:
info@bestaccessdoors.com

BA-FB-5060-TD RECESSED FOR TILE FIRE RATED - FOR WALLS

NOMINAL DOOR SIZE	A	B	C	D	E	F	LOCK
Inches (mm)							
12 x 12 (305 x 305)	11.78 (299)	11.78 (299)	14.00 (356)	14.00 (356)	12.12 (308)	12.12 (308)	1
16 x 16 (406 x 406)	15.78 (401)	15.78 (401)	18.00 (457)	18.00 (457)	16.12 (409)	14.12 (409)	1
18 x 18 (457 x 457)	17.78 (452)	17.78 (452)	20.00 (508)	20.00 (508)	18.12 (460)	16.12 (460)	1
24 x 24 (610 x 610)	23.78 (604)	23.78 (604)	26.00 (660)	26.00 (660)	24.12 (613)	18.12 (613)	1
24 x 36 (610 x 914)	35.78 (908)	23.78 (604)	26.00 (660)	38.00 (965)	24.12 (613)	24.12 (917)	2

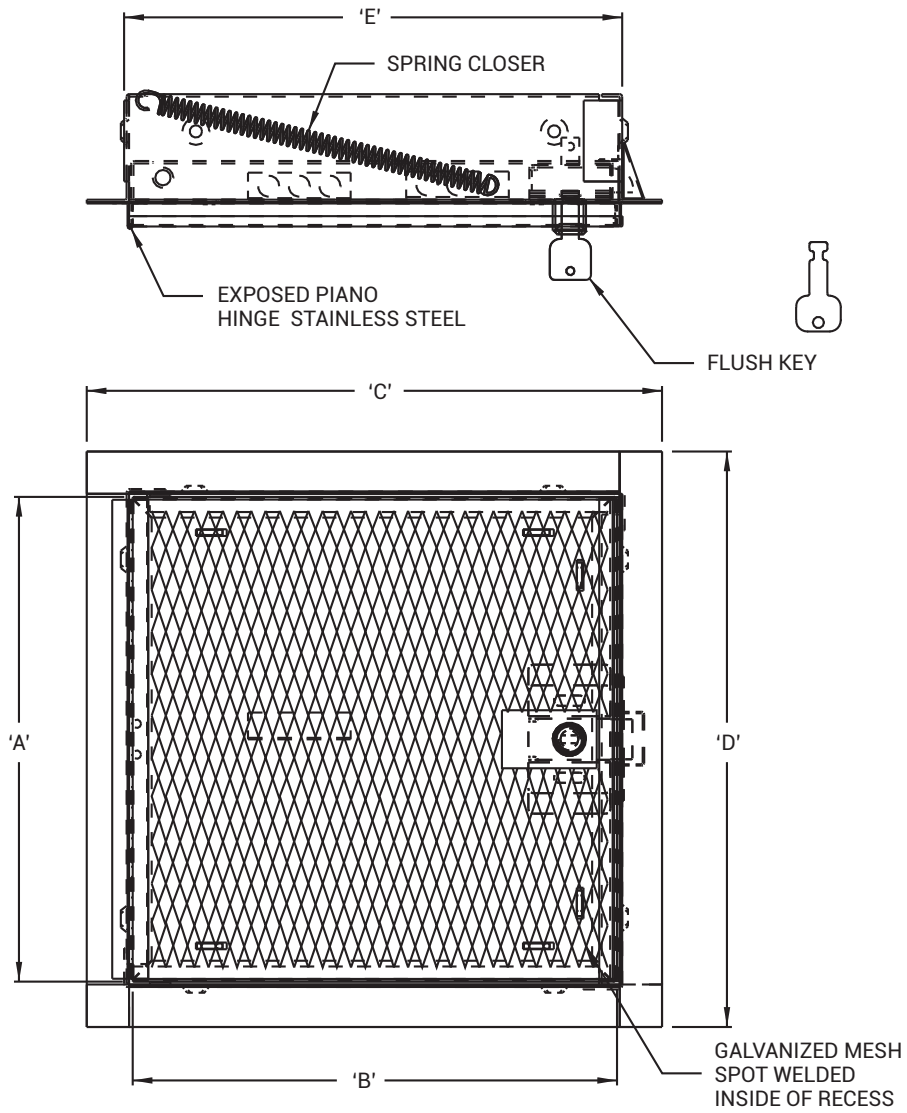

WALLS

Approved by Underwriters Laboratories (UL) for 1 1/2 hours "B" label in walls and ULC for 2 hours "B" label in walls.

