



Quality Access Doors - FAST!

SUBMITTAL/TECHNICAL DATA SHEET

APPLICATION

- Designed for interior and exterior applications where watertightness is not required
- For use when the door will not be cast into concrete, but bolted down

FEATURES

- Angle frame construction designed to be bolted into an existing opening
- Diamond plate door panel is equipped with a flush aluminum drop handle and an automatic hold open arm

SPECIFICATIONS

MATERIAL: Aluminum door and frame; stainless steel hinges and hardware

DOOR: 1/4" aluminum diamond plate reinforced for live load of 300 lb/sq. ft.

FRAME: Angle frame fabricated from aluminum extrusion

HINGE: Stainless steel butt hinges with tamperproof stainless steel bolts and nuts

OPENING DEVICE: Automatic hold open arm with red vinyl grip allows door panel to open to 90 degrees, locking door in open position, and allowing for easy control when closing door panel. When required, stainless steel compression springs can be provided to add lift assistance. Available with electrical actuators, operated by wall mounted push button switch, and remote control

STANDARD LATCH: Flush aluminum drop handle with staple for padlock. Also available: Recessed padlock provision: st/stl Slamlock

FINISH: Mill finish, with optional bituminous coating on exterior of frame

For a complete list of options visit www.BestAccessDoors.com

SKU: **BA-FFD-R**

FLOOR HATCH

RETROFIT 300 LB/SQFT



DIMENSIONS AND APPEARANCE

>> CLICK TO VIEW ADDITIONAL DETAILS AND PRICING <<

DOOR SIZE W x H INCHES (MM)	WEIGHT	
	LBS	KG
24 x 24 (610 x 610)	42	19
24 x 30 (610 x 762)	49	22
24 x 36 (610 x 914)	55	25
30 x 30 (762 x 762)	57	26
30 x 48 (762 x 1219)	80	36
36 x 36 (914 x 914)	73	33
36 x 48 (914 x 1219)	92	42
42 x 42 (1067 x 1067)	94	43
*48 x 48 (1219 x 1219)	123	56
*48 x 72 (1219 x 1829)	170	77
*60 x 60 (1524 x 1524)	177	88

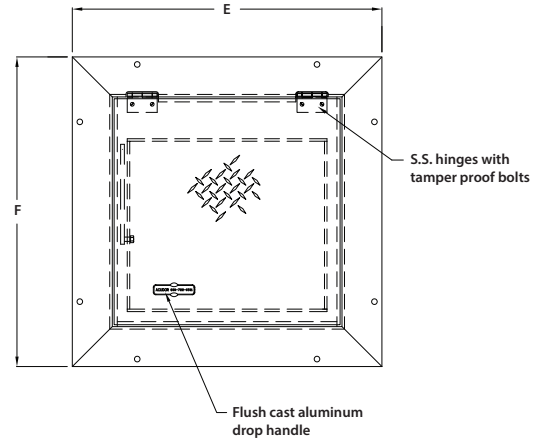

* DOUBLE LEAF
For detailed specifications see submittal sheet
MANUFACTURED BY ACUDOR

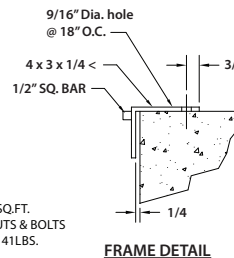
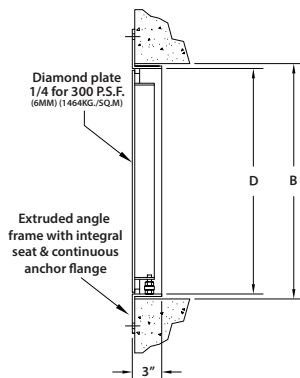

- NOTES:
- MATERIAL: ALUMINUM
 - LOADING: 300 LBS. PER SQ.FT.
 - 316 STAINLESS STEEL NUTS & BOLTS
 - APROX. HATCH WEIGHT: 41LBS.

OPTIONAL FEATURES
<input type="checkbox"/> S.S. HORIZONTAL SPRINGS
<input type="checkbox"/> S.S. SLAMLOCK
<input type="checkbox"/> BITUMINOUS PAINT ON AREA IN CONTACT WITH CONCRETE
<input type="checkbox"/> OTHERS: _____

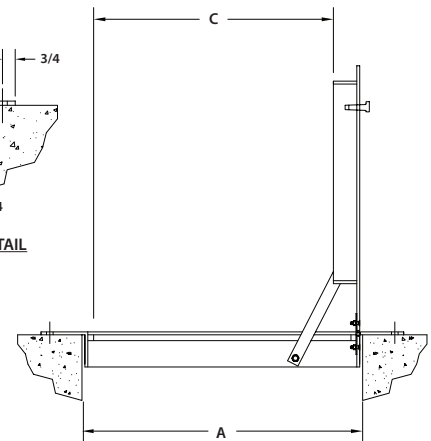

PROJECT DATA

Custom Sizes Available - Fast!

PROJECT NAME :	QTY	W	H	OPTIONS
ARCHITECT :				
DEALER :				
CONTRACTOR :				
LOCATION :	SPECIAL INSTRUCTIONS :			
DATE :				
TAGGING INSTRUCTIONS :	SUBMITTAL APPROVAL : (signature or stamp)			

Scan or Click



To view Pricing and Additional Product Info.

TELEPHONE:
1-800-483-0823
FAX:
1-888-828-6021



228 PARK AVE. S. #76520
NEW YORK, NY, 10003



WEBSITE:
www.BestAccessDoors.com
E-MAIL:
info@bestaccessdoors.com

BA-FFD-R FLOOR HATCH RETROFIT 300LB/SQFT - SINGLE LEAF

NOMINAL DOOR SIZE	FRAME OPENING		CLEAR OPENING		OVERALL SIZE		WEIGHT
	in. (mm)	A in. (mm)	B in. (mm)	C in. (mm)	D in. (mm)	F in. (mm)	
24 x 24 (610 x 610)	23 (610)	23 (610)	20 (533)	22 (584)	30 (762)	30 (762)	42 (19)
24 x 30 (610 x 762)	23 (610)	29 (762)	20 (533)	28 (737)	30 (762)	36 (914)	49 (22)
24 x 36 (610 x 914)	23 (610)	35 (914)	20 (533)	34 (889)	30 (762)	42 (1067)	55 (25)
30 x 30 (762 x 762)	29 (762)	29 (762)	26 (686)	28 (737)	36 (914)	36 (914)	57 (26)
30 x 48 (762 x 762)	29 (762)	47 (1219)	26 (686)	46 (1194)	36 (914)	54 (1372)	80 (36)
36 x 36 (914 x 914)	35 (914)	35 (762)	31 (813)	34 (889)	42 (1067)	42 (1067)	73 (33)
36 x 48 (914 x 1219)	35 (914)	47 (1219)	31 (813)	46 (1194)	42 (1067)	54 (1372)	92 (42)
42 x 42 (1067 x 1067)	41 (1067)	41 (1067)	37 (965)	40 (1041)	48 (1219)	48 (1219)	94 (43)

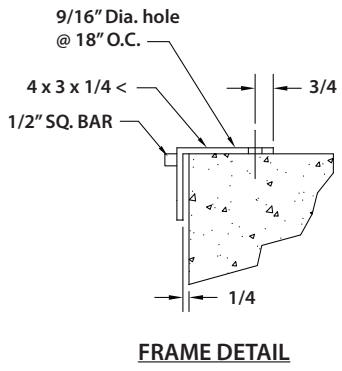
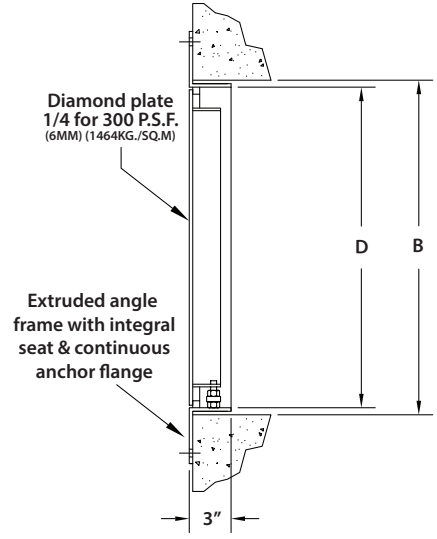
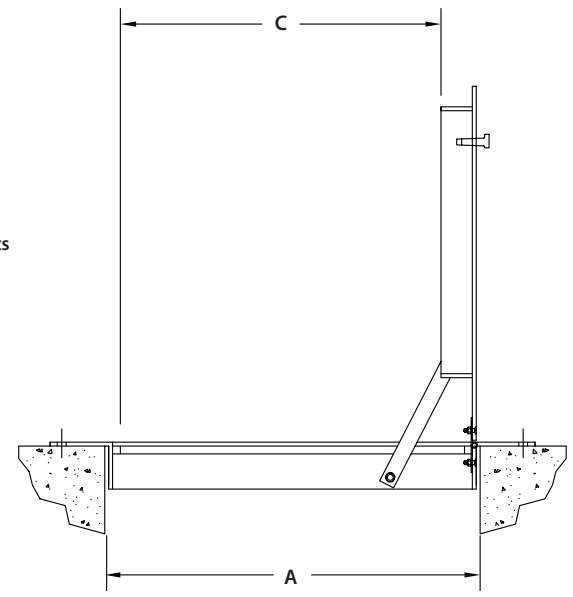
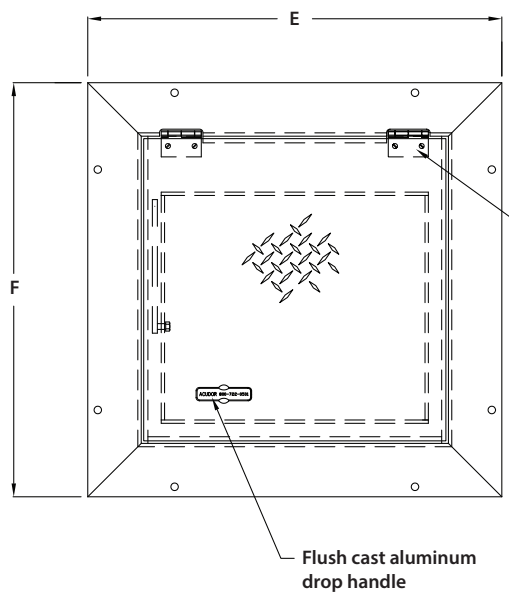

NOTES:
 • MATERIAL: ALUMINUM
 • LOADING: 300 LBS. PER SQ.FT.
 • 316 STAINLESS STEEL NUTS & BOLTS
 • APROX. HATCH WEIGHT: 41LBS.

OPTIONAL FEATURES
<input type="checkbox"/> S.S. HORIZONTAL SPRINGS
<input type="checkbox"/> S.S. SLAMLOCK
<input type="checkbox"/> BITUMINOUS PAINT ON AREA IN CONTACT WITH CONCRETE
<input type="checkbox"/> OTHERS: _____

BA-FFD-R FLOOR HATCH RETROFIT 300LB/SQFT - DOUBLE LEAF

NOMINAL DOOR SIZE	FRAME OPENING		CLEAR OPENING		OVERALL SIZE		WEIGHT
in. (mm)	A in. (mm)	B in. (mm)	C in. (mm)	D in. (mm)	E in. (mm)	F in. (mm)	LBS. (KG)
48 x 48 (1219 x 1219)	47 (1219)	47 (1219)	44 (1194)	46 (1041)	54 (1372)	54 (1372)	123 (56)
48 x 72 (1219 x 1829)	47 (1219)	71 (1829)	44 (1194)	70 (1651)	54 (1372)	78 (1981)	170 (77)
60 x 60 (1524 x 1524)	59 (1524)	59 (1524)	54 (1499)	58 (1372)	66 (1676)	66 (1676)	177 (80)

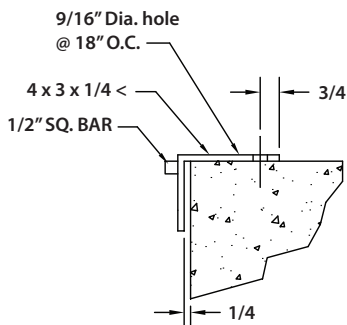
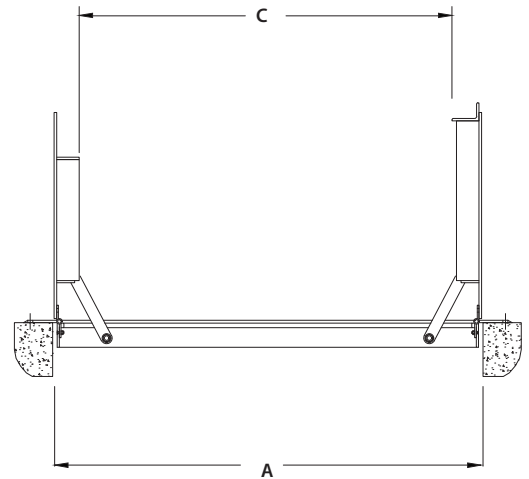
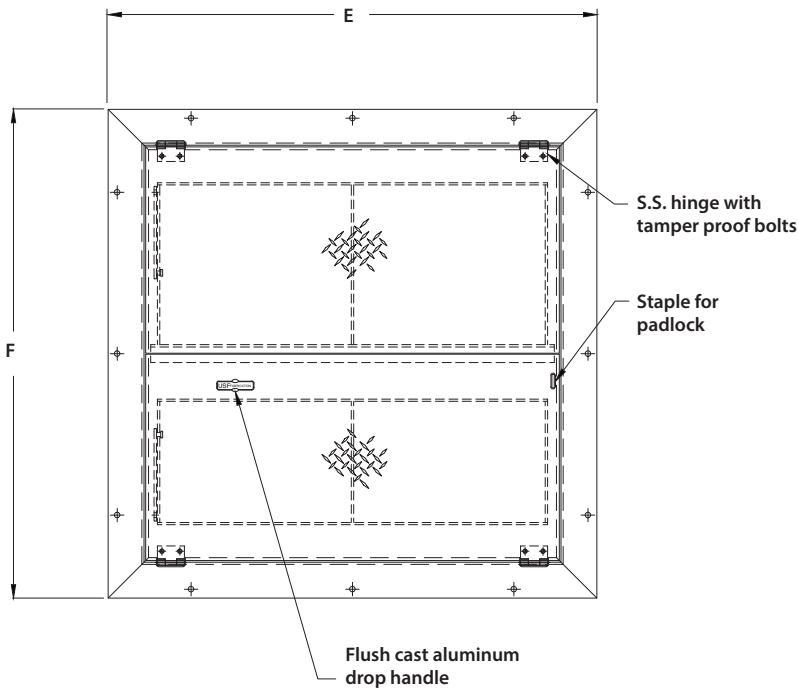

- NOTES:
- MATERIAL: ALUMINUM
 - LOADING: 300 LBS. PER SQ.FT.
 - 316 STAINLESS STEEL NUTS & BOLTS
 - APROX. HATCH WEIGHT: 41LBS.

OPTIONAL FEATURES

S.S. HORIZONTAL SPRINGS

S.S. SLAMLOCK

BITUMINOUS PAINT ON AREA IN CONTACT WITH CONCRETE

OTHERS: _____

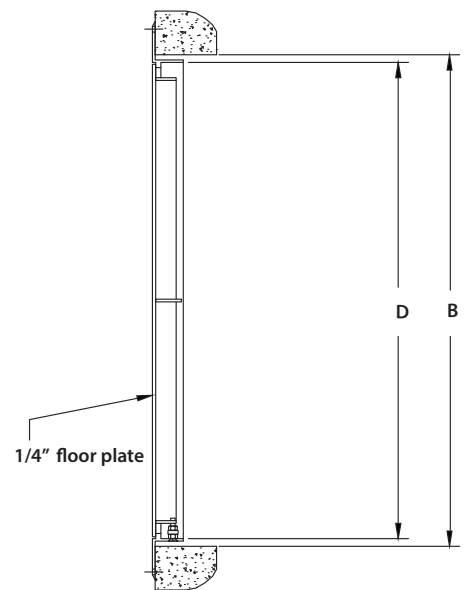

MANUFACTURED BY ACUDOR