



Quality Access Doors- FAST!

SUBMITTAL/TECHNICAL DATA SHEET

APPLICATION

- Designed to provide a gasketed fit in all types of walls and ceilings
- This door is commonly used in clean rooms, laboratories, operating rooms, etc.

FEATURES

- Gasketed access door
- Formed door panel with reinforced edges and a concealed hinge, along with open cell gasket between the door and frame
- Drywall taping bead flange.

SPECIFICATIONS

DOOR FRAME: Stainless Steel or Carbon Steel: 18 gauge door, 18 gauge mounting frame, flange to be drywall taping bead flange.

HINGE: Concealed

GASKET: Pemko S88 adhesive-backed bulb silicone gasket

STANDARD LATCH: Stainless steel Slotted Screwdriver Cam Latch.

OPTIONAL LATCHES/LOCKS: Cylinder lock & key, allen head cam latch, spanner head cam latch, torx head with security pin

FINISH: Stainless steel: #4 satin polish or Carbon Steel: 5 stage iron phosphate with prime coat of White alkyd baked-on enamel

Please note the AS has not been tested for air penetration.

For a door that has been tested for Air & Water penetration see.

ADWT Model

For a complete list of options visit www.BestAccessDoors.com



SKU: **BA-GAD-DF**

GASKETED ACCESS DOOR

WITH DRYWALL BEAD FLANGE



DIMENSIONS AND APPEARANCE

>> CLICK TO VIEW ADDITIONAL DETAILS AND PRICING <<

STANDARD SIZES:

| DOOR SIZE W x H INCHES (MM) | WEIGHT | |
|--------------------------------|--------|-----|
| | LBS | KG |
| 8 x 8 (203 x 203) | 4.0 | 1.8 |
| 12 x 12 (305 x 305) | 5.0 | 2.3 |
| 16 x 16 (406 x 406) | 7.5 | 3.4 |
| 18 x 18 (457 x 457) | 8.8 | 4.0 |
| 24 x 24 (610 x 610) | 13.9 | 6.3 |
| 24 x 36 (610 x 914) | 20.5 | 9.3 |

Wall or ceiling opening is nominal door size + 3/8" (9 mm)

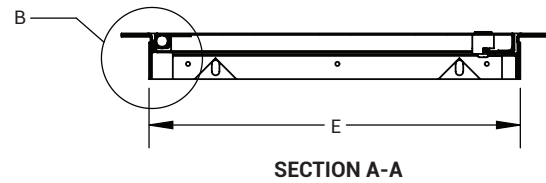

For detailed specifications see submittal sheet

MANUFACTURED BY ACUDOR

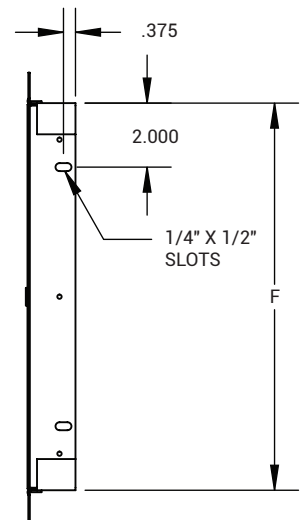
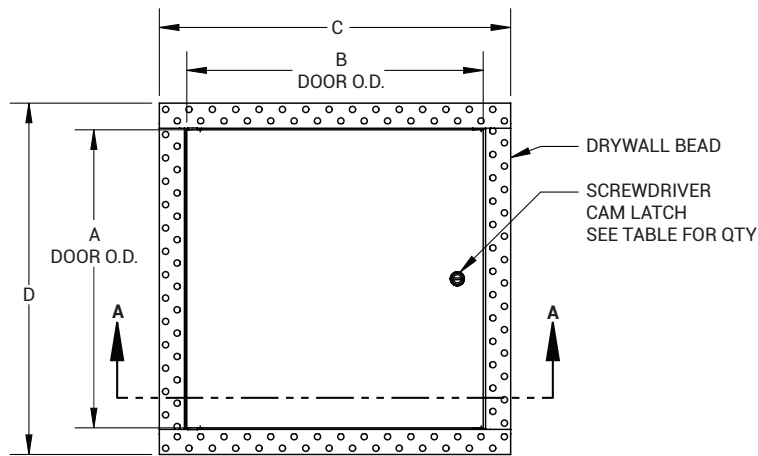

PROJECT DATA

Custom Sizes Available - Fast!

| PROJECT NAME : | QTY | W | H | OPTIONS |
|------------------------|--|---|---|---------|
| ARCHITECT : | | | | |
| DEALER : | | | | |
| CONTRACTOR : | | | | |
| LOCATION : | SPECIAL INSTRUCTIONS : | | | |
| DATE : | | | | |
| TAGGING INSTRUCTIONS : | SUBMITTAL APPROVAL : (signature or stamp) | | | |

Scan or Click



To view Pricing and Additional Product Info.

TELEPHONE:
1-800-483-0823
FAX:
1-888-828-6021



228 PARK AVE. S. #76520
NEW YORK, NY, 10003



WEBSITE:
www.BestAccessDoors.com
E-MAIL:
info@bestaccessdoors.com

BA-GAD-DF

GASKETED ACCESS DOOR WITH DRYWALL BEAD FLANGE

| NOMINAL DOOR SIZE | A | B | C | D | E | F | LATCH |
|---------------------|--------------|--------------|-------------|-------------|-------------|-------------|-------|
| in. (mm) | | | | | | | |
| 8 x 8 (203 x 203) | 7.875 (200) | 7.875 (200) | 10.00 (254) | 10.00 (254) | 8.19 (208) | 8.09 (205) | 1 |
| 12 x 12 (305 x 305) | 11.875 (302) | 11.875 (302) | 14.00 (355) | 14.00 (355) | 12.19 (310) | 12.09 (307) | 1 |
| 16 x 16 (406 x 406) | 15.875 (403) | 15.875 (403) | 18.00 (457) | 18.00 (457) | 16.19 (411) | 16.09 (409) | 2 |
| 18 x 18 (457 x 457) | 17.875 (454) | 17.875 (454) | 20.00 (508) | 20.00 (508) | 18.19 (462) | 18.09 (459) | 2 |
| 24 x 24 (610 x 610) | 23.875 (606) | 23.875 (606) | 26.00 (660) | 26.00 (660) | 24.19 (614) | 24.09 (612) | 2 |
| 24 x 36 (610 x 914) | 35.875 (911) | 23.875 (606) | 26.00 (660) | 38.00 (965) | 24.19 (614) | 36.09 (917) | 2 |

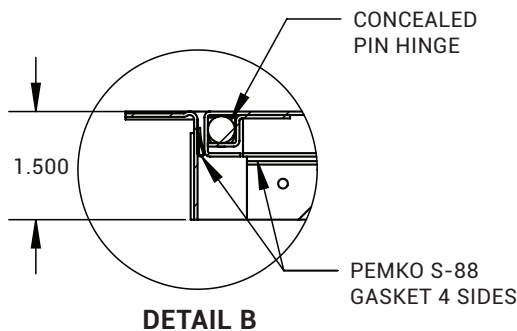
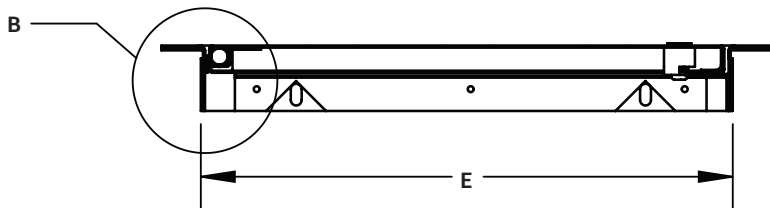
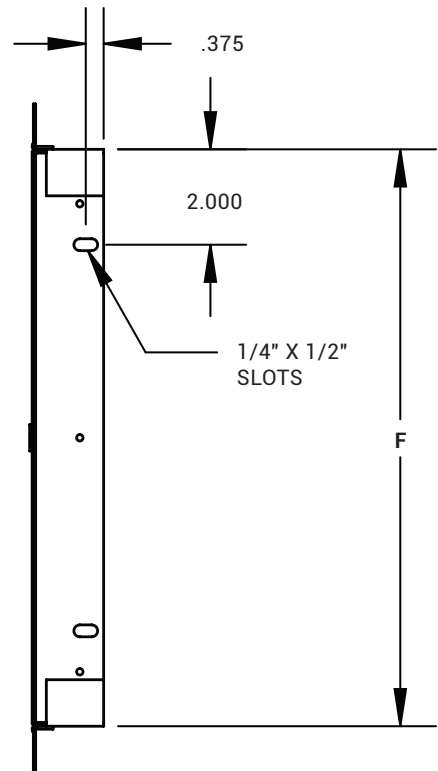
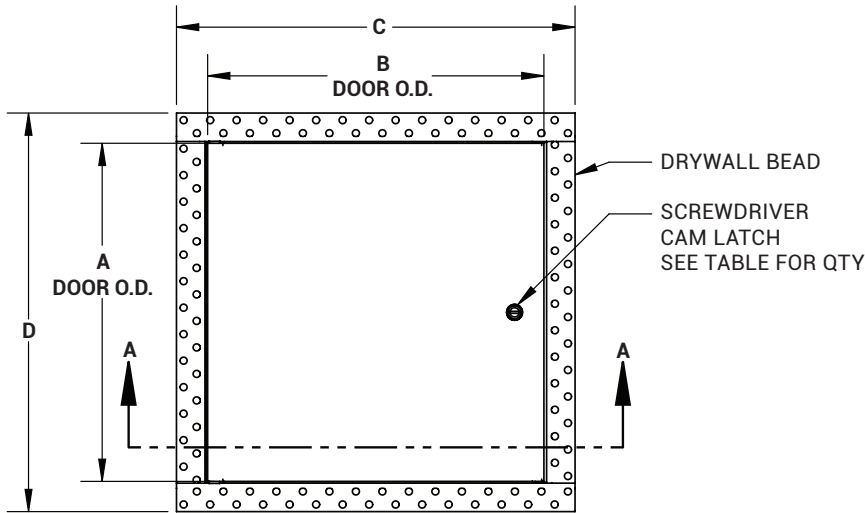

STANDARD FEATURES:
SCREWDRIVER OPERATED CAM LATCH
18GA (0.048") CARBON STEEL
PRIME COAT BAKED ENAMEL FINISH

OPTIONS
LOCK TYPE:
CYLINDER LOCK AND KEY
ALLEN HEAD CAM LATCH
SPANNER HEAD CAM LATCH
THUMB TURN LATCH
OTHER

LOCK TYPE FINISH
STAINLESS STEEL #4 SATIN POLISH
OTHER OTHER