



Quality Access Doors - FAST!

SUBMITTAL/TECHNICAL DATA SHEET

COMPONENT SYSTEM

Create the desired length using 4 ft. & 5 ft. Ladder modules along with a variety of accessories & mounting options.

FEATURES

- Provides safe, easy & economic access
- Ladders Flat Packed Kit with rapid delivery
- Modular design serving multitude of length requirements
- Easy to store & install
- Assembled on site, no special tools necessary
- Non-slip Rungs ensure secure footholds & handholds
- Standard Finish is Safety Yellow Painted, also available in Galvanized finish
- OSHA Compliant Ladder

SKU: **BA-LAD**

LADDERS - FIXED SHAFT MODULAR LADDER SYSTEM



Optional: Hinged Gate

■ SPECIFICATIONS & APPEARANCE

>> CLICK TO VIEW ADDITIONAL DETAILS AND PRICING <<

LADDER:

Material: Steel ASTM A36
Stringers: LAD-H: 2 1/2" x 3/8"
Rungs: LAD-H: 1" dia
Ladder Width: 20" inside
Length: 4' & 5' (special lengths available on request)
Weight: LAD-H: 10.5 Lbs/ft

CAGE:

Material: Steel ASTM A36
Hoops: 2" x 1/4" Th.
Straps: 1" x 3/16" Th.
Weight: 8 Lbs/ft
Height: 48"

TELESCOPIC SAFETY UPSTAND:

Material: Steel ASTM A36
Extended height: 40" from top rung

LANDING GUIDE RAIL:

Material: Steel ASTM A36
Extended height: 42" from top rung

HINGED GATE:

Material: 12 Ga. Steel ASTM A36
Height: 7'

NOTE:

All application requirements are different depending on site conditions. We provided our Ladder System in modular parts to allow a perfect fit for all uses. All components are sold separately. See a parts list and sample reference on the back of this page.



Optional: Hinged Gate

For a complete list of options visit www.BestAccessDoors.com

■ PROJECT DATA

Custom Sizes Available - Fast!

Scan or Click



To view Pricing and Additional Product Info.

PROJECT NAME :	QTY	W	H	OPTIONS
ARCHITECT :				
DEALER :				
CONTRACTOR :				
LOCATION :	SPECIAL INSTRUCTIONS :			
DATE :				
TAGGING INSTRUCTIONS :	SUBMITTAL APPROVAL : (signature or stamp)			

TELEPHONE:
1-800-483-0823
FAX:
1-888-828-6021



228 PARK AVE. S. #76520
NEW YORK, NY, 10003



WEBSITE:
www.BestAccessDoors.com
E-MAIL:
info@bestaccessdoors.com

BA-LAD FIXED SHAFT MODULAR LADDER SYSTEM - PARTS GUIDE

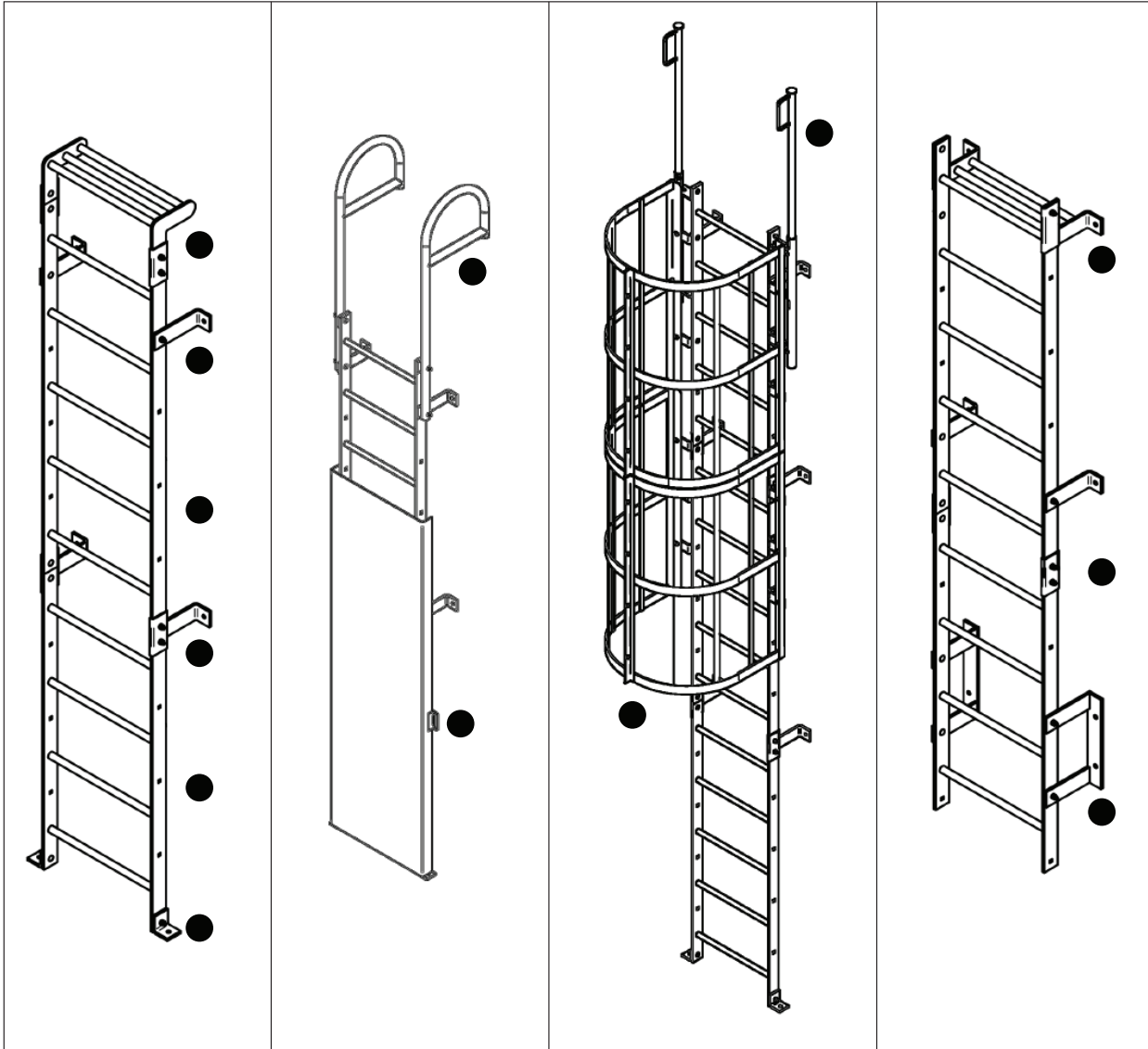

Sample configurations shown above are for illustrative purposes only. All components are sold separately

MANUFACTURED BY ACUDOR

ITEM	DESCRIPTION	PART#
01	Interior Landing Step c/w hardware *	LAD-LS-1
02	Wall Bracket c/w hardware * (8 1/2" x 5/16")	LAD-WB-1
03	4'L Ladder	LAD-H-4
	5'L Ladder	LAD-H-5
04	Wall Bracket Splice c/w hardware * (8 1/2" x 5/16")	LAD-WBS-1
05	Floor Bracket c/w hardware * (2 3/4" x 2 3/4" x 5/16")	LAD-FB-1
06	4'Landing Guide Rail c/w mounting hardware *	LAD-LG-1

ITEM	DESCRIPTION	PART#
07	7' Hinged Gate c/w Hinges, Lock Hasp & hardware*	LAD-HG-1
08	Telescoping Safety Upstand c/w hardware * (2')	LAD-TSPU-2
09	48" Safety Cage c/w hardware *	LAD-CG-1
10	Exterior Landing Step c/w hardware *	LAD-LS-2
11	Splice Plate c/w hardware * (10 Ga)	LAD-SP-1
12	Off-Floor Wall Bracket c/w hardware * (8 1/2" x 14 1/2" x 5/16")	LAD-WBO-2

Additional component material specifications available on request

* All mounting hardware mounts parts to ladder and not ladder to the wall or floor. Carriage Bolts (1/2-13 x 1 1/2") are included

BA-LAD STEEL LADDER - HEAVY DUTY

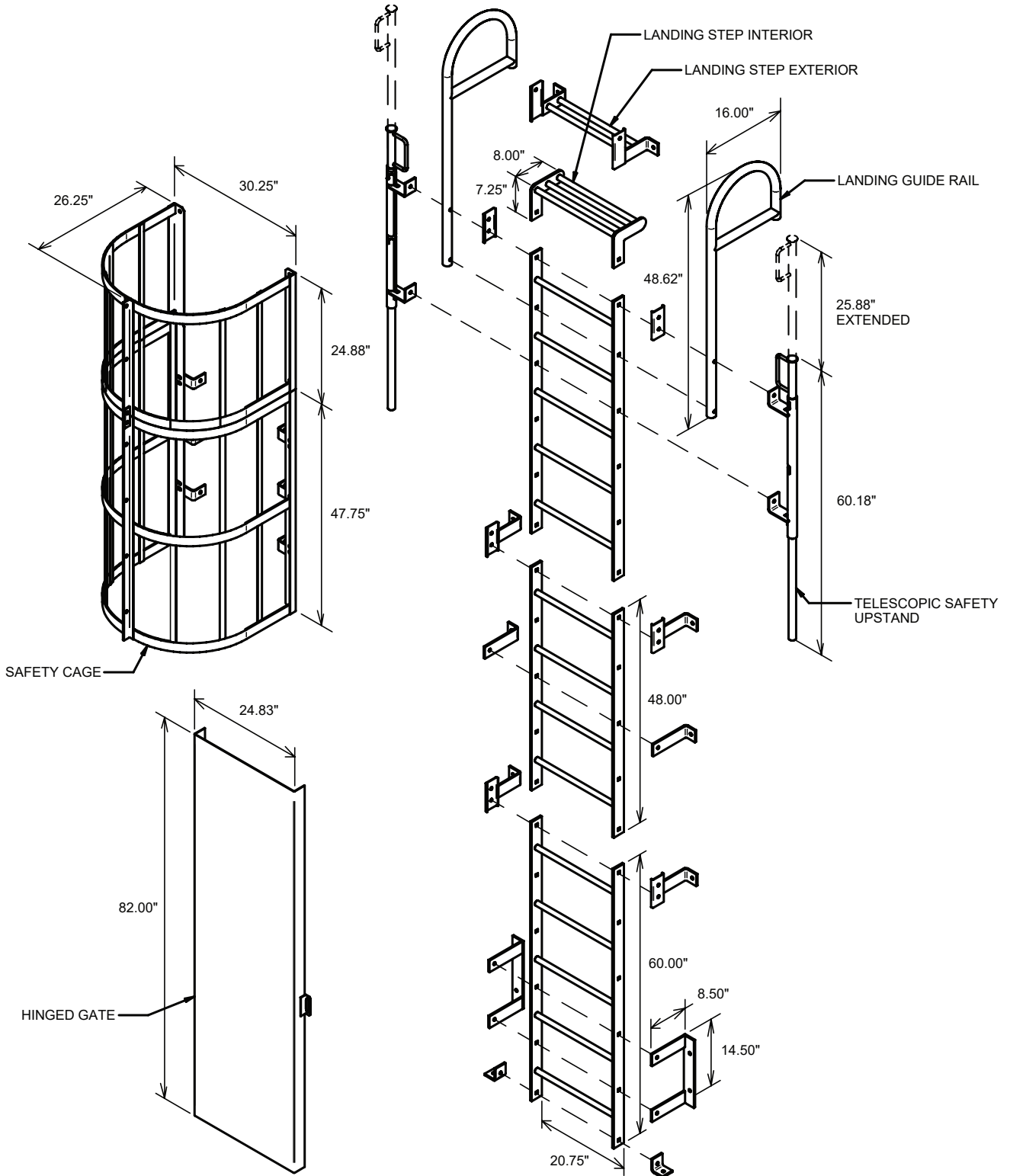

HEAVY DUTY LADDER (2-1/2" X 3/8" STRINGER, 1" DIA. RUNG)
STANDARD LADDER MODULES: 48.00" AND 60.00" (CAN COMBINE TO DIFFERENT LENGTHS)
FINISH: POWDER COATED TO SAFELY YELLOW AND GALVANIZED