



Quality Access Doors- FAST!

SUBMITTAL/TECHNICAL DATA SHEET

APPLICATION

Lightweight aluminum access door for walls and ceilings

FEATURES

- Mitered aluminum frame provides an architecturally pleasing appearance
- Aluminum door panel is lined with 3/4" polystyrene insulation
- All aluminum construction is ideal for exterior applications, and specific interior applications where corrosion or moisture is a concern
- Gasketing between the door and frame

SPECIFICATIONS

DOOR / DOOR FRAME:

Aluminum: .064 door and .080 frame
Flush to edge of frame, 1-5/16" mitered aluminum extrusion flange with 1-1/2" deep mounting frame

HINGE: Doors with width 24" or less to have concealed pin hinge. Doors with width over 24" to have continuous aluminum piano hinge with exposed knuckle, set to open to 180 degrees.

INSULATION: 3/4" Type 3 Expanded Polystyrene (EPS) Foil Lined Insulation, with a 3.18 R Value.

GASKET: 1/8" x 3/8" closed cell neoprene gasketing

STANDARD LATCH: Screwdriver operated cam latch

OPTIONAL LATCHES/LOCKS: Cylinder lock & key

FINISH: Mill finish



SKU: **BA-LT-4000**

UNIVERSAL FLUSH

LIGHTWEIGHT ALUMINUM

DIMENSIONS AND APPEARANCE

>> CLICK TO VIEW ADDITIONAL DETAILS AND PRICING <<

STANDARD SIZES:

DOOR SIZE W x H INCHES (MM)	WEIGHT	
	LATCHES	LBS KG
8 x 8 (203 x 203)	1	1.8 0.8
10 x 10 (254 x 254)	1	2.3 1.0
12 x 12 (305 x 305)	1	2.9 1.3
14 x 14 (355 x 355)	1	3.5 1.6
16 x 16 (400 x 400)	1	4.2 1.9
18 x 18 (457 x 457)	1	4.9 2.2
24 x 24 (610 x 610)	1	7.3 3.3
24 x 36 (610 x 914)	2	10.4 4.7
24 x 48 (610 x 1220)	2	13.5 6.1
30 x 30 (762 x 762)	2	11.7 5.3
36 x 36 (914 x 914)	2	15.3 6.9
36 x 48 (914 x 1220)	2	19.3 8.8
48 x 48 (1220 x 1220)	4	24.3 11.0
60 x 48 (1524 x 1220)	4	34.0 15.4
72 x 48 (1830 x 1220)	4	40.0 18.1

Wall opening is normal door size plus +5/8" (16mm)
For detailed specifications see submittal sheet

MANUFACTURED BY ACUDOR

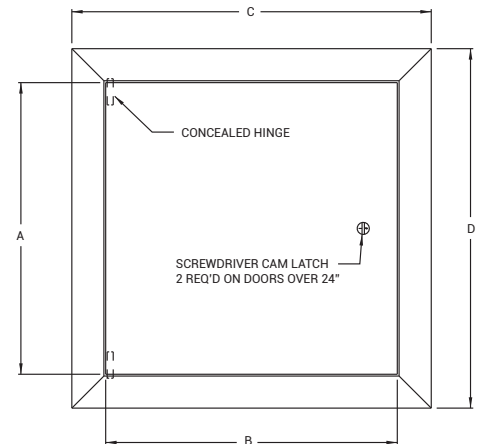
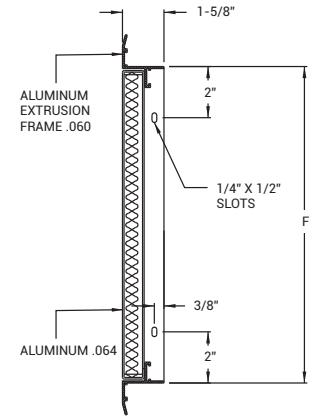
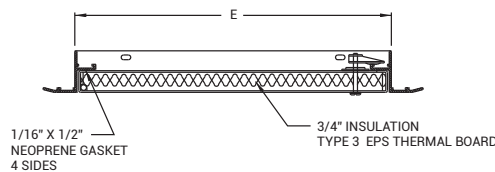

For a complete list of options visit
www.BestAccessDoors.com

PROJECT DATA

Custom Sizes Available - Fast!

Scan or Click



To view Pricing and Additional Product Info.

PROJECT NAME :	QTY	W	H	OPTIONS
ARCHITECT :				
DEALER :				
CONTRACTOR :				
LOCATION :	SPECIAL INSTRUCTIONS :			
DATE :				
TAGGING INSTRUCTIONS :	SUBMITTAL APPROVAL : (signature or stamp)			

TELEPHONE:
1-800-483-0823
FAX:
1-888-828-6021



228 PARK AVE. S. #76520
NEW YORK, NY, 10003



WEBSITE:
www.BestAccessDoors.com
E-MAIL:
info@bestaccessdoors.com

BA-LT-4000

LIGHT WEIGHT ALUMINUM

NOMINAL DOOR SIZE	A	B	C	D	E	F	SCREWS
in. (mm)							
8 x 8 (203 x 203)	8.062 (205)	8.062 (205)	10.855 (276)	10.855 (276)	8.375 (213)	8.375 (213)	1
10 x 10 (254 x 254)	10.062 (256)	10.062 (256)	12.855 (327)	12.855 (327)	10.375 (264)	10.375 (264)	1
12 x 12 (305 x 305)	12.062 (307)	12.062 (307)	14.855 (377)	14.855 (377)	12.375 (314)	12.375 (314)	1
14 x 14 (355 x 355)	14.062 (358)	14.062 (358)	16.855 (428)	16.855 (428)	14.375 (365)	14.375 (365)	1
18 x 18 (457 x 457)	18.062 (459)	18.062 (459)	20.855 (530)	20.855 (530)	18.375 (467)	18.375 (467)	1
24 x 24 (610 x 610)	24.062 (612)	24.062 (612)	26.855 (682)	26.855 (682)	24.375 (619)	24.375 (619)	1
24 x 36 (610 x 914)	36.062 (917)	24.062 (612)	26.855 (682)	38.855 (987)	24.375 (619)	36.375 (924)	2
24 x 48 (610 x 1220)	48.062 (1221)	24.062 (612)	26.855 (682)	50.855 (1292)	24.375 (619)	48.375 (1229)	2

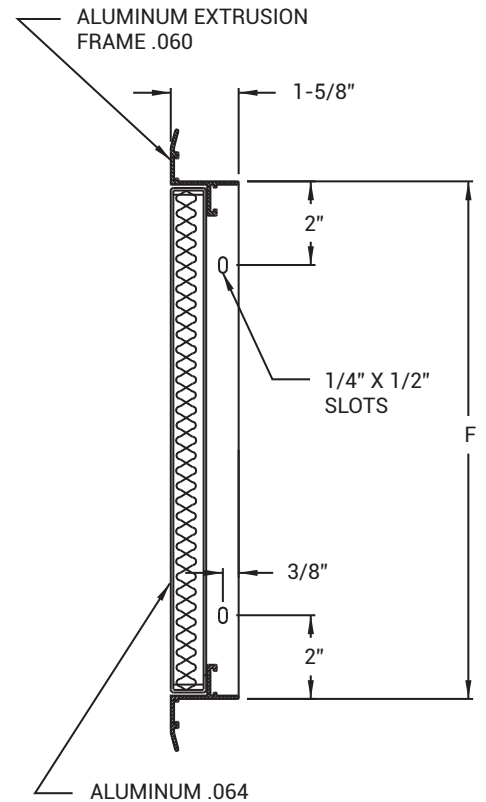
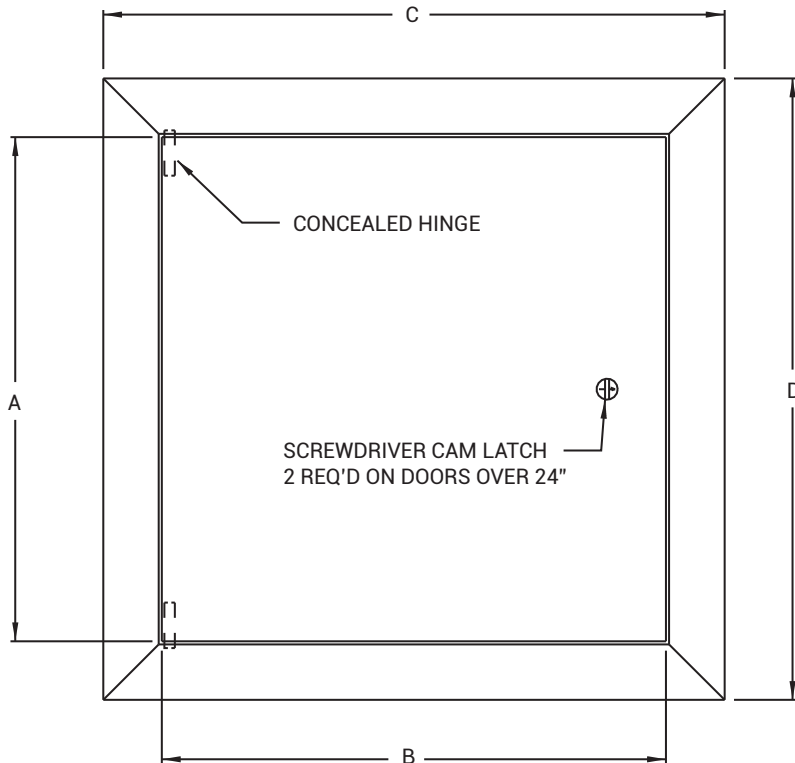
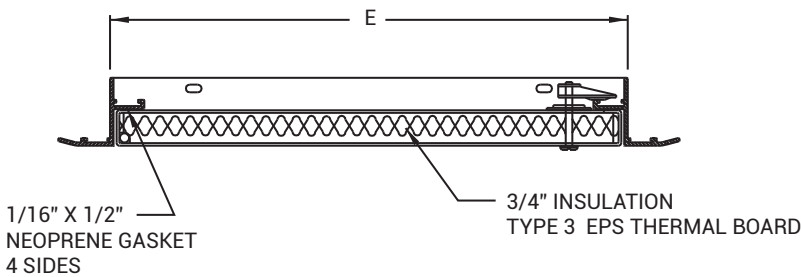

BA-LT-4000

PIANO HINGE LIGHT WEIGHT ALUMINUM

NOMINAL DOOR SIZE	A	B	C	D	E	F	SCREWS
in. (mm)							
30 x 30 (762 x 762)	30.062 (205)	30.000 (762)	32.855 (835)	32.855 (835)	30.375 (772)	30.375 (772)	2
36 x 36 (914 x 914)	36.062 (256)	36.000 (914)	38.855 (987)	38.855 (987)	36.375 (924)	36.375 (924)	2
36 x 48 (914 x 1210)	48.062 (307)	36.000 (914)	38.855 (987)	50.855 (1292)	36.375 (924)	48.375 (1229)	2

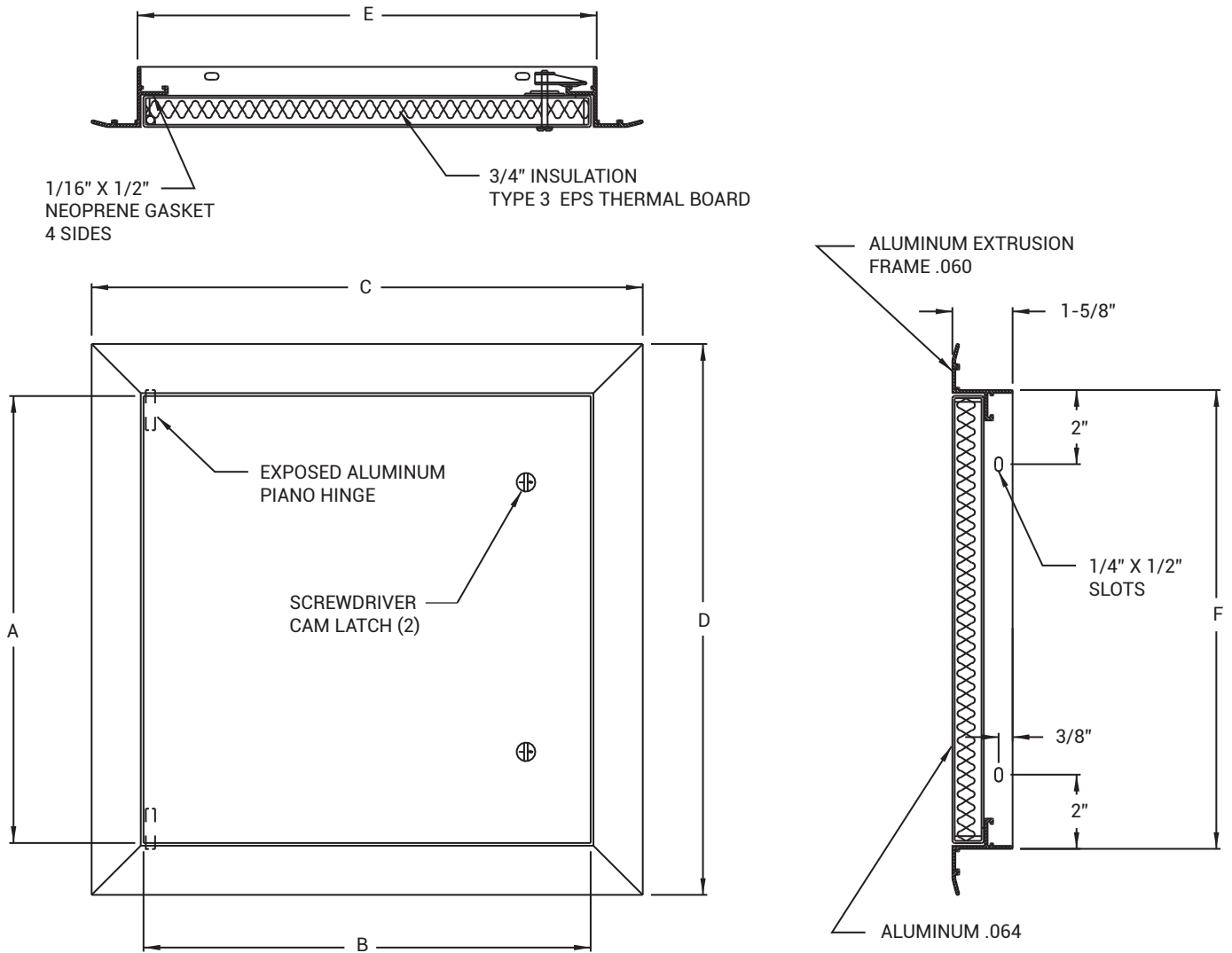

MANUFACTURED BY ACUDOR

BA-LT-4000

DOUBLE LEAF LIGHT WEIGHT ALUMINUM

NOMINAL DOOR SIZE	A	B	C	D	E	F	SCREWS
in. (mm)							
* 48 x 48 (1220 x 1220)	48.062 (1221)	48.062 (1221)	50.855 (1292)	50.855 (1292)	48.375 (1229)	48.375 (1229)	2
60 x 48 (1524 x 1220)	48.062 (1221)	60.062 (1524)	62.855 (1597)	50.855 (1292)	60.375 (1534)	48.375 (1229)	2
60 x 60 (1524 x 1524)	60.062 (1525)	60.062 (1525)	62.855 (1597)	62.855 (1597)	60.375 (1534)	60.375 (1534)	2
72 x 48 (1830 x 1220)	48.062 (1221)	72.062 (1829)	74.855 (1901)	50.855 (1292)	72.375 (1838)	48.375 (1229)	2

* CONCEALED PIN HINGE USED

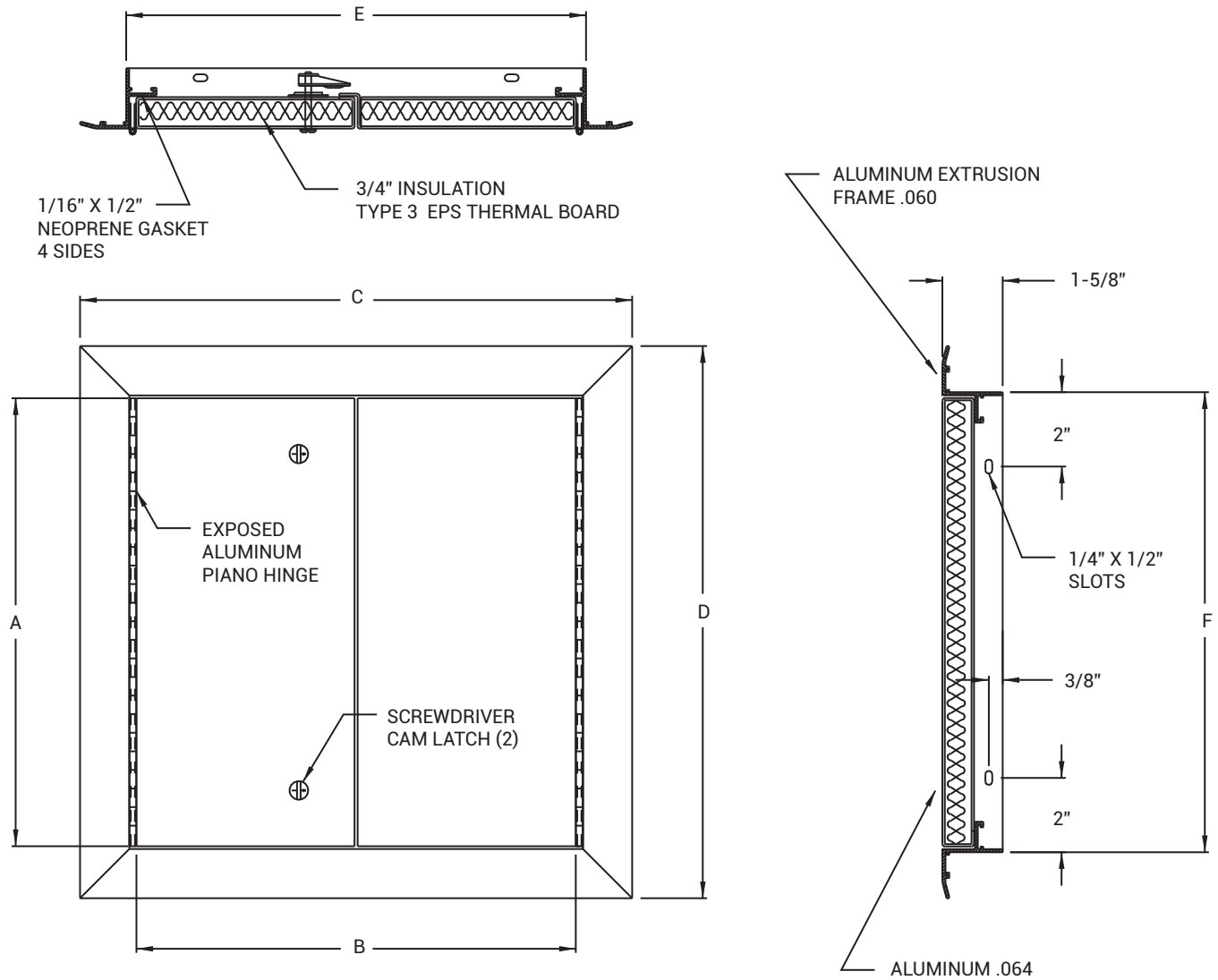

MANUFACTURED BY ACUDOR