



Quality Access Doors- FAST!

# SUBMITTAL/TECHNICAL DATA SHEET

## APPLICATION

Acudor Domed Roof Hatches are designed to provide convenient, economical access to the roof of a building. The Polycarbonate Domes provide the benefit of a skylight

## FEATURES

- G90 Galv. Steel
- Stainless Steel Hardware
- Clear, bronze, white, combination polycarbonate double-skin dome

## OPTIONAL FEATURES

- Stainless Steel cover, curb
- Louvered Curbs
- Curb Mounted Units
- Curb pitch corrected for sloped roof
- All Aluminum construction, cover and curb

## SPECIFICATIONS

**COVER:** Double-skin construction ("in box type design") with 1" Polyiso (R-6) insulation and a continuous EPDM foam weather/draft seal gasket that is attached to the inside of cover to provide a flush, tight fit. Designed to support a live load of 40lbs./sq. ft., the cover is 1/8" thick aluminum, with a 20 gauge aluminum inside liner

**CURB:** 14 gauge galvanized steel with 1" thick Polyiso (R-6) insulation with Fiberglass liner at curb exterior. Curb is 12" high, with 3.375" wide bottom flange and pre-drilled mounting holes

**HINGE:** Heavy duty galvanized steel pintle hinges with 3/8" SS pin

**OPENING:** Gas spring operators allow cover to open and close with ease. Stainless Steel inside pull handle allows for easy control when closing cover.

**DOOR LATCH:** Self latching, Stainless Steel outside T handle with stainless steel inside lock and lever assembly. Unit also has inside and outside padlock provisions.

**FINISH:** Material is prepared with an iron phosphate wash, followed by a rust inhibiting primer, and then a baked on polyester enamel grey paint

SKU: **BA-RHGDD**

# GALVANIZED DOMED ROOF HATCH

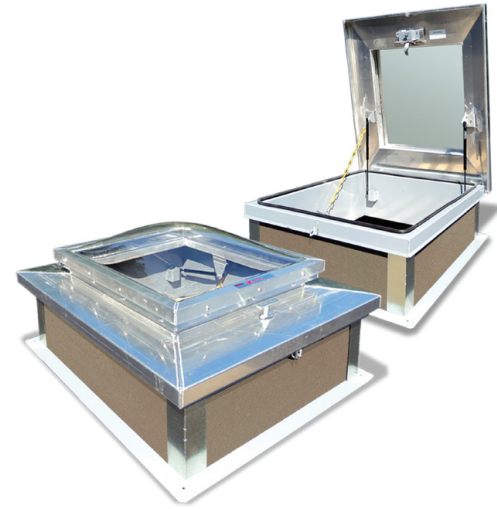

## DIMENSIONS AND APPEARANCE

>> [CLICK TO VIEW ADDITIONAL DETAILS AND PRICING](#) <<

### STANDARD SIZES:

MODEL	CURB ID L&W INCHES (MM)	WEIGHT	
		LBS	KG
GD3232	24 x 24 (610 x 610)	125	56.8
GD3238	24 x 36 (610 x 914)	135	61.4
GD3244	30 x 30 (762 x 762)	140	63.5
GD3838	30 x 36 (762 x 914)	155	70.5
GD3844	36 x 36 (914 x 914)	170	77.3

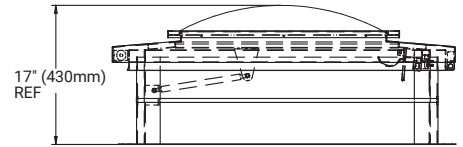

**ASSEMBLY NOTE:**  
UNIT SHALL BE COMPLETELY ASSEMBLED AS SHOWN AND SUPPLIED TO JOB READY FOR INSTALLATION

**FINISH:** MILL FINISH

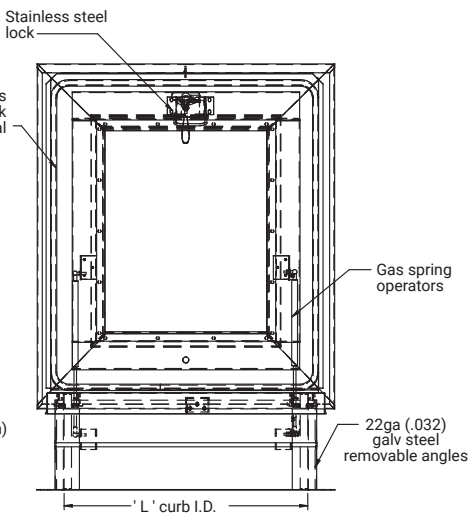
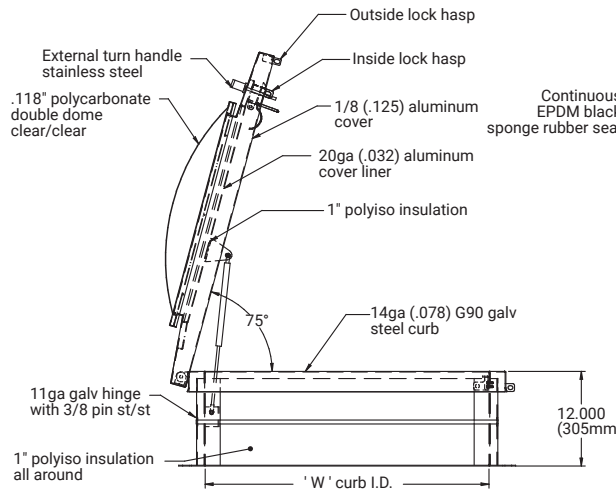

For a complete list of options visit [www.BestAccessDoors.com](http://www.BestAccessDoors.com)

## PROJECT DATA

Custom Sizes Available - Fast!

Scan or Click



PROJECT NAME :	QTY	W	H	OPTIONS
ARCHITECT :				
DEALER :				
CONTRACTOR :				
LOCATION :	SPECIAL INSTRUCTIONS :			
DATE :				
TAGGING INSTRUCTIONS :	SUBMITTAL APPROVAL : (signature or stamp)			

To view Pricing and Additional Product Info.

TELEPHONE:  
1-800-483-0823  
FAX:  
1-888-828-6021



228 PARK AVE. S. #76520  
NEW YORK, NY, 10003



WEBSITE:  
[www.BestAccessDoors.com](http://www.BestAccessDoors.com)  
E-MAIL:  
[info@bestaccessdoors.com](mailto:info@bestaccessdoors.com)

**BA-RHGDD**

**DOMED ROOF HATCH  
GALVANIZED**

QTY	OPENING WIDTH 'W'	OPENING LENGTH 'L'	QTY	OPENING WIDTH 'W'	OPENING LENGTH 'L'
	24" (610mm)	24" (610mm)		36" (914mm)	30" (762mm)
	36" (914mm)	24" (610mm)		36" (914mm)	36" (914mm)
	30" (762mm)	30" (762mm)		48" (1219mm)	48" (1219mm)

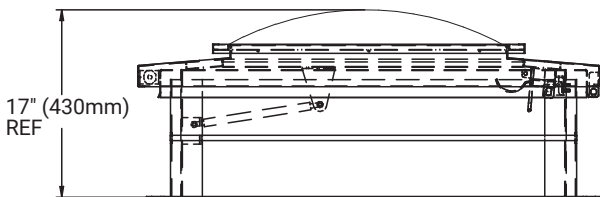
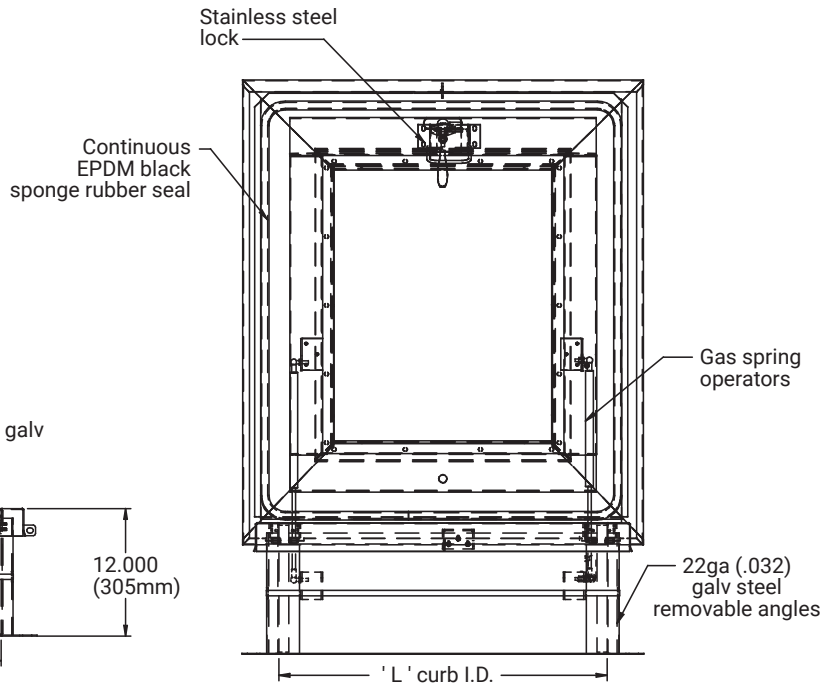
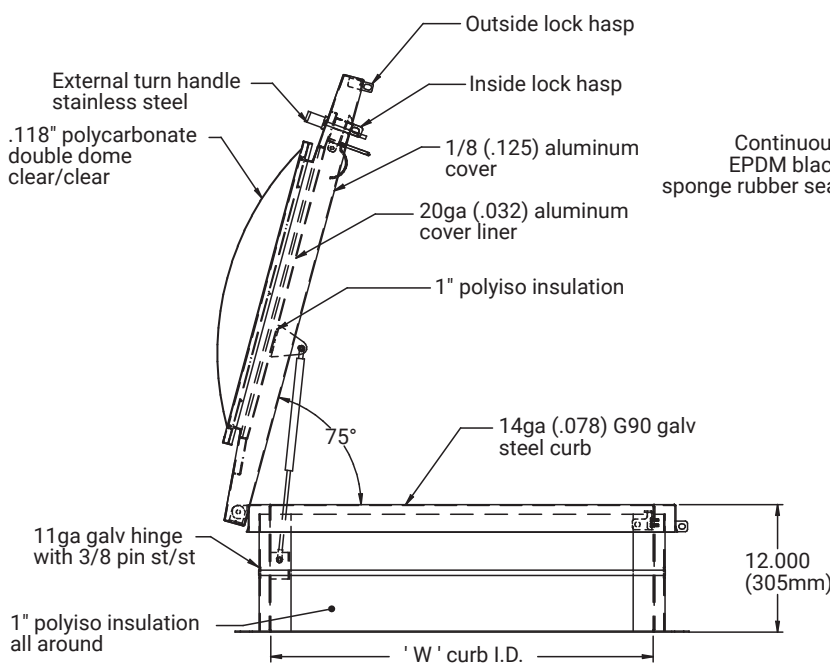

**ASSEMBLY NOTE:**  
 UNIT SHALL BE COMPLETELY ASSEMBLED  
 AS SHOWN AND SUPPLIED TO JOB READY  
 FOR INSTALLATION

**FINISH:** MILL FINISH

**MANUFACTURED BY ACUDOR**