



Quality Access Doors - FAST!

# SUBMITTAL/TECHNICAL DATA SHEET

## APPLICATION

Designed for interior and exterior applications that require an access opening that will blend in with the surrounding floor material

## FEATURES

- To keep the floor material from cracking or chipping within the door panel, the securing screws are located in the flange of the mounting frame
- FT-8080: Recessed 1/8" to accommodate carpeting and vinyl tile
- FT-8080-1: Recessed 1" to accommodate ceramic tile/concrete

## SPECIFICATIONS

MATERIAL: Aluminum

DOOR FT-8080: 1/4" smooth aluminum plate reinforced for live load of 150 lb/sq. ft., recessed 1/8" for carpet/vinyl tile

DOOR FT-8080-1: 1/4" smooth aluminum plate reinforced for live loads of 150 lb/sq. ft. / recessed 1" for ceramic tile/concrete

FRAME: 1-1/2" x 1-1/4" aluminum angle with mounting holes in top flange

STANDARD LATCH: Door panel is secured to frame with 1/4" x 1" flat head screws

FINISH: Mill finish

For a complete list of options visit [www.BestAccessDoors.com](http://www.BestAccessDoors.com)

SKU: **BA-RRFD-18**

**REMOVABLE FLOOR HATCH RECESSED 1/8"**

FOR VINYL TILE/CARPET

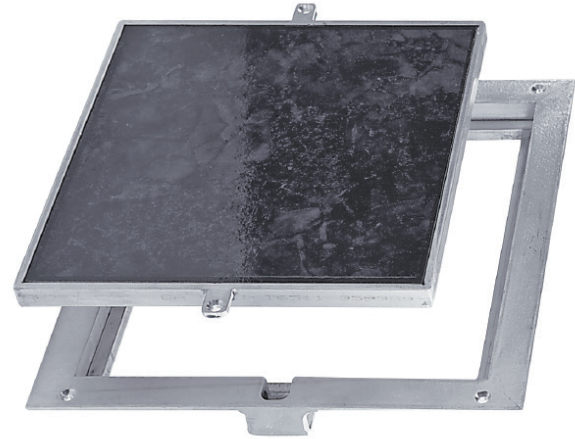

## DIMENSIONS AND APPEARANCE

>> CLICK TO VIEW ADDITIONAL DETAILS AND PRICING <<

DOOR SIZE W x H INCHES (MM)		WEIGHT LBS KG	
8 x 8	(203 x 203)	6	3
12 x 12	(305 x 305)	9	4
18 x 18	(457 x 457)	18	8
24 x 24	(610 x 610)	36	16

For detailed specifications see submittal sheet

MANUFACTURED BY ACUDOR

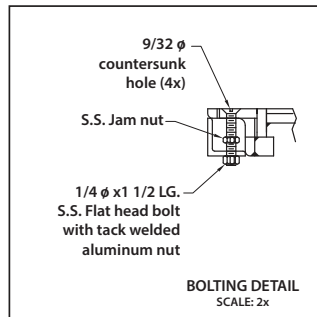
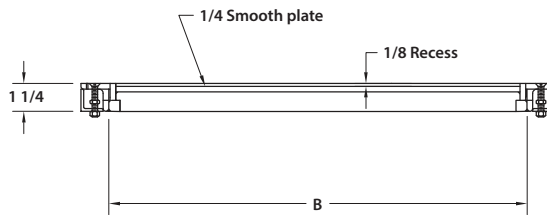

- NOTES:
- MATERIAL: ALUMINUM
  - LOADING: 150 LBS. PER SQ. FT.
  - 316 STAINLESS STEEL NUTS & BOLTS

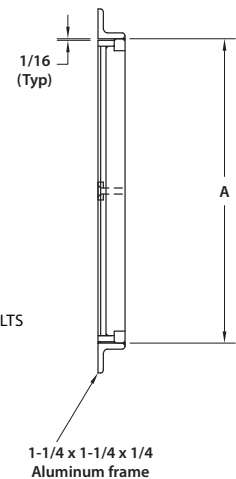
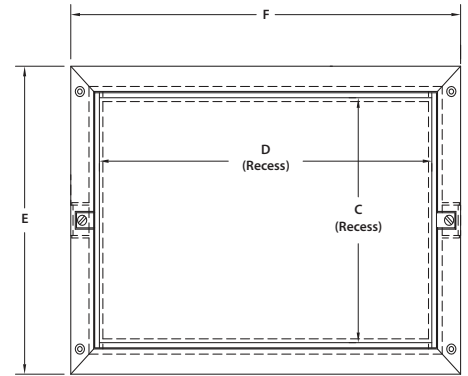

## PROJECT DATA

Custom Sizes Available - Fast!

PROJECT NAME :	QTY	W	H	OPTIONS
ARCHITECT :				
DEALER :				
CONTRACTOR :				
LOCATION :	SPECIAL INSTRUCTIONS :			
DATE :				
TAGGING INSTRUCTIONS :	SUBMITTAL APPROVAL : (signature or stamp)			

Scan or Click



To view Pricing and Additional Product Info.

TELEPHONE:  
1-800-483-0823  
FAX:  
1-888-828-6021



228 PARK AVE. S. #76520  
NEW YORK, NY, 10003



WEBSITE:  
[www.BestAccessDoors.com](http://www.BestAccessDoors.com)  
E-MAIL:  
[info@bestaccessdoors.com](mailto:info@bestaccessdoors.com)

# BA-RRFD-18 REMOVABLE FLOOR HATCH RECESSED 1/8" FOR VINYL TILE/CARPET

NOMINAL DOOR SIZE	FRAME LD.		RECEIVING AREA		OVERALL SIZE		WEIGHT
	in. (mm)	A in. (mm)	B in. (mm)	C in. (mm)	D in. (mm)	E in. (mm)	F in. (mm)
8 x 8	8-3/4 (222)	8-3/4 (222)	8.125 (206)	8.125 (206)	11.250 (286)	11.250 (286)	6 (3)
12 x 12	12-3/4 (324)	12-3/4 (324)	12.125 (308)	12.125 (308)	15.250 (387)	15.250 (387)	9 (4)
18 x 18	18-3/4 (476)	18-3/4 (476)	18.125 (460)	18.125 (460)	21.250 (540)	21.250 (540)	18 (8)
24 x 24	24-3/4 (629)	24-3/4 (629)	24.125 (613)	24.125 (613)	27.250 (692)	27.250 (692)	36 (16)

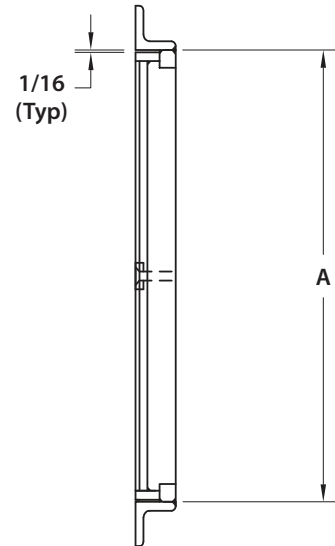
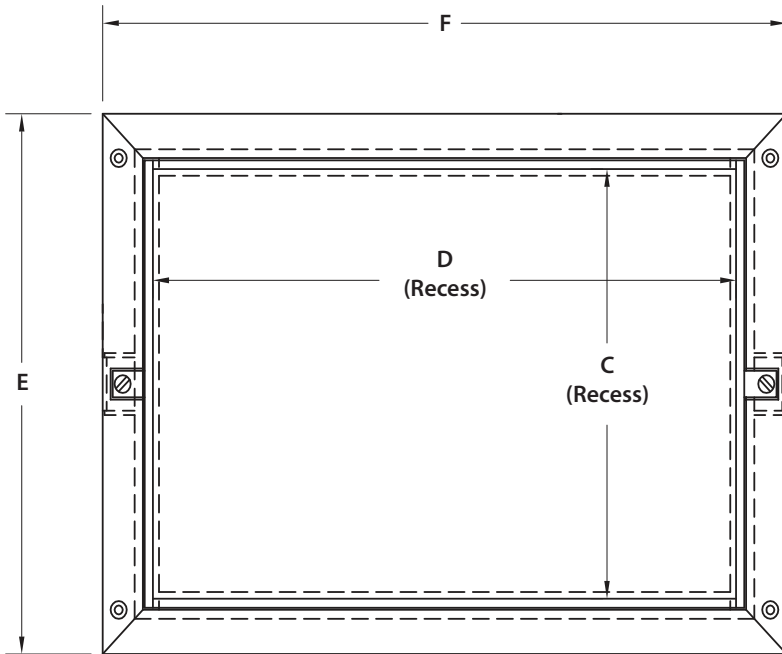

1-1/4 x 1-1/4 x 1/4 Aluminum frame

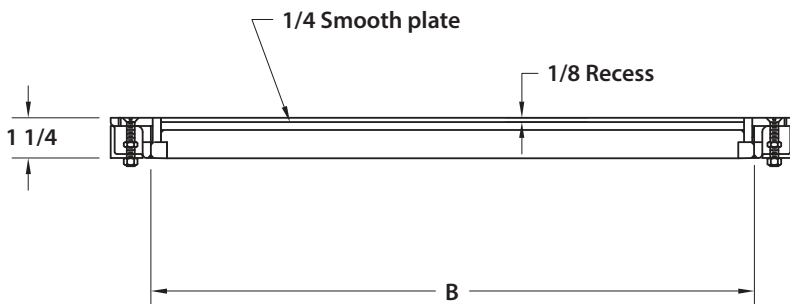

- NOTES:
- MATERIAL: ALUMINUM
  - LOADING: 150 LBS. PER SQ. FT.
  - 316 STAINLESS STEEL NUTS & BOLTS

