



Quality Access Doors- FAST!

SUBMITTAL/TECHNICAL DATA SHEET

APPLICATION

Acudor Smoke Vents are designed to provide an economical solution for fire ventilation. These UL-Listed, automatic Smoke Vents provide invaluable assistance to firefighters by evacuating deadly smoke, heat, and gases from a burning building

FEATURES

- 14 gauge G90 Galvanized Steel
- 12" high insulated curb
- High performance gas springs
- Inside and Outside manual release
- UL Listed Fusible or McCabe Resettable Links

OPTIONAL FEATURES

- Curb mount or Metal Building Flange
- Double-Dome Co-Polyester lids for daylighting
- Louvered curb for ventilation

SPECIFICATIONS

COVER: Double-skin construction ("in box type design") with 1" cellulose insulation and a continuous EPDM foam weather/draft seal gasket that is attached to the inside of cover to provide a flush, tight fit. Designed to support a live load of 40lbs./sq. ft., the cover is 14 gauge galvanized steel with a 22 gauge galvanized steel inside liner.

CURB: 14 gauge galvanized steel with 1" thick fiberboard roof insulation at curb exterior. Curb is 12" high, with 3.375" wide bottom flange and pre-drilled mounting holes.

HINGE: Heavy duty galvanized steel / aluminum pintle hinges with 3/8" pin

OPENING: Gas spring operators allow cover to open and close with ease. Inside and outside release allows for manual lid operation.

DOOR LATCH: Self latching Slam Latch. Supplied standard with 165° UL Listed Fusible Link. Resettable McCabe link available.

FINISH: Galvanized Steel: baked on polyester enamel paint

SKU: **BA-SVG-DL**

GALVANIZED UL LISTED SMOKE VENT

DOUBLE LEAF



DIMENSIONS AND APPEARANCE

>> CLICK TO VIEW ADDITIONAL DETAILS AND PRICING <<

MODEL	CURB ID L&W INCHES (MM)	WEIGHT	
		LBS	KG
SVG4848	48 x 48 (1219 x 1219)	180	82
SVG4872	48 x 72 (1219 x 1219)	230	104
SVG4890	48 x 90 (1219 x 1219)	240	109
SVG4896	48 x 96 (1219 x 1219)	250	113
SVG6060	60 x 60 (1219 x 1219)	235	106
SVG6072	60 x 72 (1219 x 1219)	240	109
SVG6090	60 x 90 (1219 x 1219)	300	136
SVG6096	60 x 96 (1219 x 1219)	310	141

For detailed specifications see submittal sheet

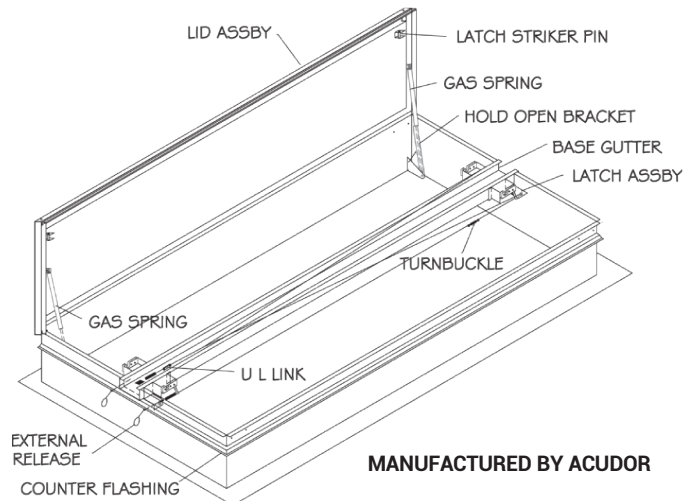

MANUFACTURED BY ACUDOR

For a complete list of options visit www.BestAccessDoors.com

PROJECT DATA

Custom Sizes Available - Fast!

Scan or Click



PROJECT NAME :	QTY	W	H	OPTIONS
ARCHITECT :				
DEALER :				
CONTRACTOR :				
LOCATION :	SPECIAL INSTRUCTIONS :			
DATE :				
TAGGING INSTRUCTIONS :	SUBMITTAL APPROVAL : (signature or stamp)			

TELEPHONE:
1-800-483-0823
FAX:
1-888-828-6021



228 PARK AVE. S. #76520
NEW YORK, NY, 10003



WEBSITE:
www.BestAccessDoors.com
E-MAIL:
info@bestaccessdoors.com

To view Pricing and Additional Product Info.

BA-SVG-DL

UL LISTED SMOKE VENT GALVANIZED

QTY	OPENING WIDTH 'W'	OPENING LENGTH 'L'	QTY	OPENING WIDTH 'W'	OPENING LENGTH 'L'
	48" (1219mm)	48" (1219mm)		60" (1524mm)	60" (1524mm)
	48" (1219mm)	72" (1829mm)		60" (1524mm)	72" (1829mm)
	48" (1219mm)	90" (2286mm)		60" (1524mm)	90" (2286mm)
	48" (1219mm)	96" (2286mm)		60" (1524mm)	96" (2438mm)

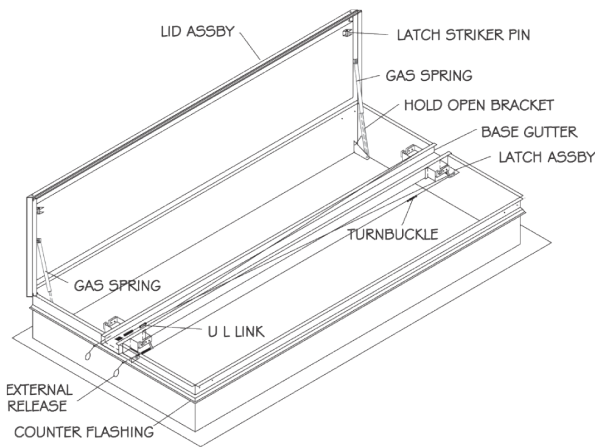

SPECIFICATIONS:

- Fully Welded & Assembled Aluminum Curb
- 4" x 4" x 3/16" Galvanized Steel OSHA Compliant Safety Screen Option
- Base options include self flashing, curb mount and metal building
- 1" Rigid Insulation R7.2
- Full perimeter EPDM bulb gaskets
- Lids open against a 10 PSF live load
- Lid uplift rating 30 PSF
- Hinges and latches 12 gauge
- Latches rated for 90 PSF uplift
- UL listed fusible or McCabe resettable links
- Inside and outside manual releases
- High performance gas springs with hold open

