



Quality Access Doors- FAST!

SUBMITTAL/TECHNICAL DATA SHEET

SKU: **BA-WSR**

WEATHER STRIP REMOVABLE ACCESS DOORS



Weather Strip Removable Access Doors are designed with flush gaskets between the panel and frame to ensure flush air seal in all types of walls and ceilings.

Note: Door has NOT been tested for air tightness.

Door and Frame shall be 16 gauge galvanized steel with a white prime coat finish.

Frame is a one piece construction 1" wide and produces perfect concealment of the rough wall openings. Wall frame is provided with 1/4" mounting holes for fastening within the furred spaces allowing faster installation and giving maximum clearance.

Door is fully removable and held in place by multiple latches.

Latch is a screwdriver operated. Finish is a white prime coat suitable for painting.

GUIDE SPECIFICATION

Access door and frame shall be gasketed between the panel and frame to ensure flush air seal in all types of walls and ceilings. Access door and frame shall be fabricated from 16 gauge, galvanized steel with a white prime coat finish. The door shall have rounded safety corners. Frame shall be one piece construction with no miters or welds on the face. Latches shall be screwdriver operated. Finish shall be a white prime coat suitable for painting.

MODEL NUMBER AND OPTIONS SELECTION

BASE MODEL NUMBER

- WSR Weather Strip Removable Access Door

SUFFIX OPTIONS

- AKL Allen Key Latch
- TH 'T' Handle
- CL Cylinder Lock (one per door)
- CLD Cylinder Lock with Dust Shutter (one per door)
- SS Stainless Steel Construction (Type 304 No. 4 Satin Finish)

For a complete list of options visit www.BestAccessDoors.com

DIMENSIONS AND APPEARANCE

>> CLICK TO VIEW ADDITIONAL DETAILS AND PRICING <<

DOOR SIZE (W X H)	WALL OPENING	LATCHES	WEIGHT
WSR 8" x 8"	8-1/2" x 8-1/2"	4	3.0 lbs.
WSR 10" x 10"	10-1/2" x 10-1/2"	4	4.0 lbs.
WSR 12" x 12"	12-1/2" x 12-1/2"	4	5.5 lbs.
WSR 14" x 14"	14-1/2" x 14-1/2"	4	6.0 lbs.
WSR 16" x 16"	16-1/2" x 16-1/2"	4	7.5 lbs.
WSR 18" x 18"	18-1/2" x 18-1/2"	4	9.0 lbs.
WSR 24" x 24"	24-1/2" x 24-1/2"	4	15.0 lbs.

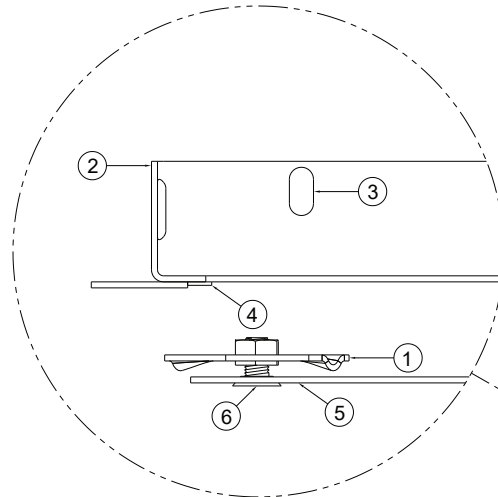
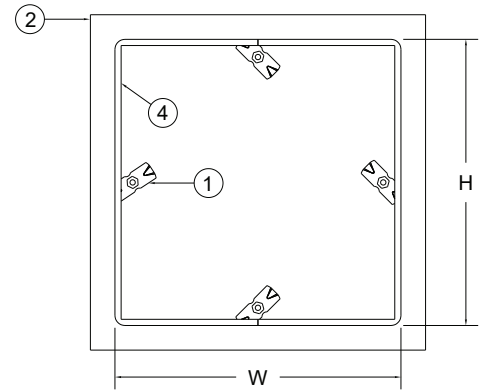

1. FRAME MOUNTING HOLE
2. LATCH ASSEMBLY
3. FRAME
4. WEATHER STRIP GASKET
5. 16 GAUGE DOOR PANEL
6. SLOTTED FLAT HEAD SCREW

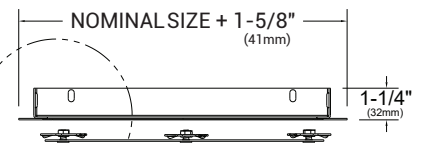

PROJECT DATA

Custom Sizes Available - Fast!

PROJECT NAME :	QTY	W	H	OPTIONS
ARCHITECT :				
DEALER :				
CONTRACTOR :				
LOCATION :	SPECIAL INSTRUCTIONS :			
DATE :	SUBMITTAL APPROVAL : (signature or stamp)			
TAGGING INSTRUCTIONS :				

Scan or Click



To view Pricing and Additional Product Info.

TELEPHONE:
1-800-483-0823
FAX:
1-888-828-6021



228 PARK AVE. S. #76520
NEW YORK, NY, 10003



WEBSITE:
www.BestAccessDoors.com
E-MAIL:
info@bestaccessdoors.com