



Quality Access Doors - FAST!

SUBMITTAL/TECHNICAL DATA SHEET

DESCRIPTIONS

Double leaf domed equipment hatches add more daylight into your building with domed equipment hatches.

SPECIFICATIONS

MATERIAL:

STEEL - 14 gauge galvanized with 22 gauge liner.

ALUMINUM - 11 gauge with 22 gauge liner.

FINISH: Gray prime coat on steel, silver prime coat on aluminum.

DOMES: Clear over white acrylic domes.

GASKETING: Continuous bulb neoprene door seal.

INSULATION: 1" fiberglass insulation in cover, 1/2" rigid fiberboard on curb.

HINGES: Heavy-duty hinges.

HOLD-OPEN ARM: Galvanized steel automatic hold-open arms with red vinyl handles.

LATCHES: Two point universal spring latches on each cover with exterior and interior handles.

SPRING: Pressure intensifiers with compression springs provide lift assistance.

SIZES:

Minimum: 72" x 72"

Maximum: 72" x 96"

CLEAR OPENING: Minus 8" on width and minus 8" on length.

SKU: BA-DDRHA

HATCH DOMED EQUIPMENT



DIMENSIONS AND APPEARANCE

>> CLICK TO VIEW ADDITIONAL DETAILS AND PRICING <<

STANDARD SIZE CHART:

MODEL	MATERIAL	CURB OPENING	CLEAR OPENING
REHVA-7272ST	Aluminum	72" x 72"	64" x 64"
REHVA-7296ST	Aluminum	72" x 96"	64" x 88"

OPTIONS:

- CD - Double Wall Curb
- H18 - 18" High Curb
- IS - 1" Fiberboard Insulated Curb
- IT - 2" Polyiso Insulated Curb
- IW - 1" x 6" Wood Nailer Top/Polyiso Bottom of Curb
- VPCW - Double Polycarbonate Clear over White Dome
- VAW - Acrylic Single Dome White
- VPW - Polycarbonate Single White
- CM - Curb Mount
- SS - Stainless Hardware

FINISH:

- GT - Powder Coat Gray Texture (Std for REHVG)
- ST - Powder Coat Silver Texture (Std for REHVA, REHVA)

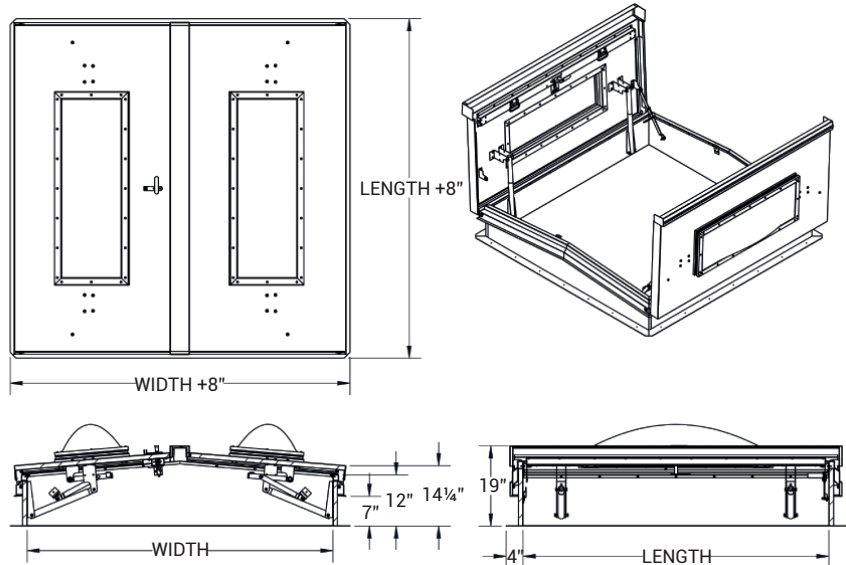

For a complete list of options visit www.BestAccessDoors.com

PROJECT DATA

Custom Sizes Available - Fast!

PROJECT NAME :	QTY	W	H	OPTIONS
ARCHITECT :				
DEALER :				
CONTRACTOR :				
LOCATION :	SPECIAL INSTRUCTIONS :			
DATE :	SUBMITTAL APPROVAL : (signature or stamp)			
TAGGING INSTRUCTIONS :				

Scan or Click



To view Pricing and Additional Product Info.

TELEPHONE:
1-800-483-0823
FAX:
1-888-828-6021



228 PARK AVE. S. #76520
NEW YORK, NY, 10003



WEBSITE:
www.BestAccessDoors.com
E-MAIL:
info@bestaccessdoors.com